

Electric Airless Sprayers

3A0157A
ENG

- For Portable Airless Spraying of Architectural Coatings and Paints -

3300 psi (227 bar, 22.7 MPa) Maximum Working Pressure



IMPORTANT SAFETY INSTRUCTIONS

Read all warnings and instructions in this manual. Save these instructions.

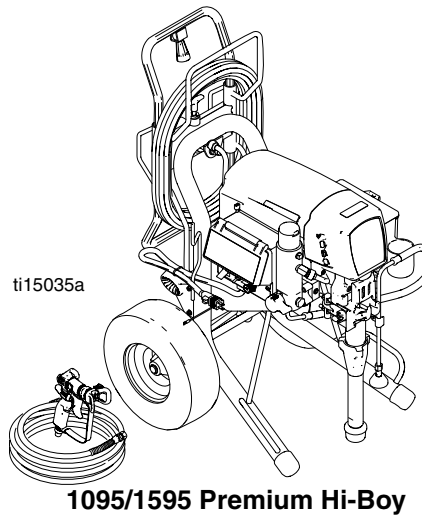
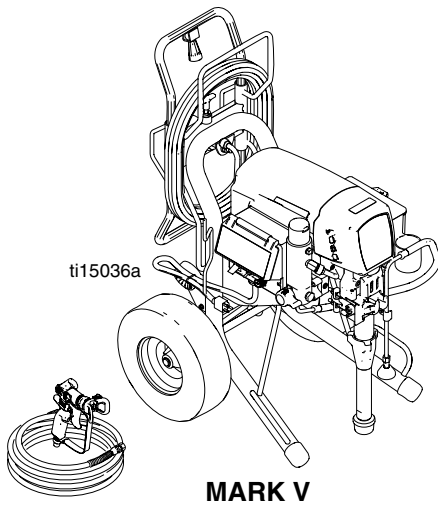
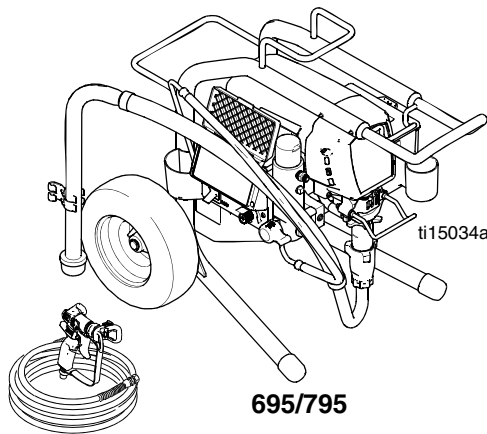
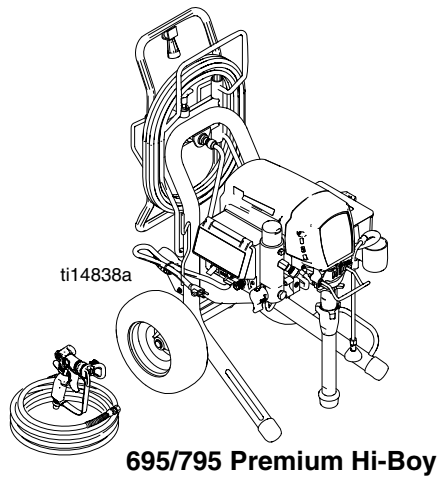

Related Manuals:
Operation 3A0156
Parts 3A0158
Gun 311861



Models:

Models:

695 ULTRA MAX III			
Model	QuikReel	Hi-Boy	Lo-Boy
258719	✓	✓	
258720		✓	
258722			✓
258872			✓
258873		✓	
258874			✓
258876		✓	
258877	✓	✓	
826124	✓	✓	
826125		✓	
826127			✓
795 ULTRA MAX III			
Model	QuikReel	Hi-Boy	Lo-Boy
258723	✓	✓	
258724		✓	
258878	✓	✓	
258879			✓
258881		✓	
258882	✓	✓	
826128	✓	✓	
826129		✓	
1095 ULTRA MAX III			
Model	QuikReel	Hi-Boy	Lo-Boy
258727	✓	✓	
258728		✓	
258883	✓	✓	
258884		✓	
258886	✓	✓	
826130	✓	✓	
826131		✓	
1595 ULTRA MAX III			
Model	QuikReel	Hi-Boy	Lo-Boy
258763	✓	✓	
258764		✓	
258765	✓	✓	
258766		✓	
826132	✓	✓	
826133		✓	
826134	✓	✓	
826135		✓	
MARK IV			
Model	QuikReel	Hi-Boy	Lo-Boy
258729	✓	✓	
MARK V			
Model	QuikReel	Hi-Boy	Lo-Boy
258730	✓	✓	
258887	✓	✓	

Table of Contents

Models:	2	Displacement Pump Replacement 695/795/Mark V ...	31
Table of Contents	3	Removal	31
Warnings	4	Installation	32
Component Identification	7	Displacement Pump Replacement 1095/1595/Mark V .	33
Pressure Relief Procedure	8	Removal	33
Grounding	9	Installation	34
Power Requirements	9	Hose Reel	36
Extension Cord	9	Removal	36
Pails	9	Installation	37
Troubleshooting	10	Reed Switch Replacement	38
Mechanical/Fluid Flow	10	Removal	38
Electrical	13	Installation	38
240 VAC and 110 VAC Motor Control Board	21	Wiring Diagram	39
240 VAC Filter Board	23	120V Models:	39
Pressure Adjust Potentiometer	24	120V Models (with 15/20 Amp Switch):	40
Pressure Control Transducer	25	240V Models:	41
Drive and Bearing Housing Replacement	27	Graco Standard Warranty	44
Disassembly	27		
Assembly	27		
Motor Replacement	29		
Removal	29		
Installation	29		

Warnings

The following warnings are for the setup, use, grounding, maintenance and repair of this equipment. The exclamation point symbol alerts you to a general warning and the hazard symbol refers to procedure-specific risks. Refer back to these warnings. Additional, product-specific warnings may be found throughout the body of this manual where applicable.

Grounding Instructions

This product must be grounded. In the event of an electrical short circuit, grounding reduces the risk of electric shock by providing an escape wire for the electric current. This product is equipped with a cord having a grounding wire with an appropriate grounding plug. The plug must be plugged into an outlet that is properly installed and grounded in accordance with all local codes and ordinances.

WARNING



GROUNDING

This product must be grounded. In the event of an electrical short circuit, grounding reduces the risk of electric shock by providing an escape wire for the electric current. This product is equipped with a cord having a grounding wire with an appropriate grounding plug. The plug must be plugged into an outlet that is properly installed and grounded in accordance with all local codes and ordinances.

- Improper installation of the grounding plug is able to result in a risk of electric shock.
- When repair or replacement of the cord or plug is required, do not connect the grounding wire to either flat blade terminal.
- The wire with insulation having an outer surface that is green with or without yellow stripes is the grounding wire.
- Check with a qualified electrician or serviceman when the grounding instructions are not completely understood, or when in doubt as to whether the product is properly grounded.
- Do not modify the plug provided; if it does not fit the outlet, have the proper outlet installed by a qualified electrician.
- This product is for use on a nominal 120V circuit and has a grounding plug similar to the plug illustrated in the figure below.

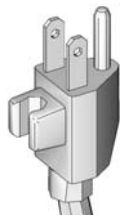

- Only connect the product to an outlet having the same configuration as the plug.
- Do not use an adapter with this product.

Extension Cords:

- Use only a 3-wire extension cord that has a 3-blade grounding plug and a 3-slot receptacle that accepts the plug on the product.
- Make sure your extension cord is not damaged. If an extension cord is necessary, use 12 AWG (2.5 mm²) minimum to carry the current that the product draws.
- An undersized cord results in a drop in line voltage and loss of power and overheating.

WARNING
**FIRE AND EXPLOSION HAZARD**









Flammable fumes, such as solvent and paint fumes, in work area can ignite or explode. To help prevent fire and explosion:

- Do not spray flammable or combustible materials near an open flame or sources of ignition such as cigarettes, motors, and electrical equipment.
- Paint or solvent flowing through the equipment is able to result in static electricity. Static electricity creates a risk of fire or explosion in the presence of paint or solvent fumes. All parts of the spray system, including the pump, hose assembly, spray gun, and objects in and around the spray area shall be properly grounded to protect against static discharge and sparks. Use Graco conductive or grounded high-pressure airless paint sprayer hoses.
- Do not clean with materials having flash points lower than 70° F (21° C). Use water-based material or mineral spirits-type material only. For complete information about your fluid, request the MSDS from the fluid distributor or retailer.
- Verify that all containers and collection systems are grounded to prevent static discharge.
- Connect to a grounded outlet and use grounded extensions cords. Do not use a 3-to-2 adapter.
- Do not use a paint or a solvent containing halogenated hydrocarbons.
- Keep spray area well-ventilated. Keep a good supply of fresh air moving through the area. Keep pump assembly in a well ventilated area. Do not spray pump assembly.
- Do not smoke in the spray area.
- Do not operate light switches, engines, or similar spark producing products in the spray area.
- Keep area clean and free of paint or solvent containers, rags, and other flammable materials.
- Know the contents of the paints and solvents being sprayed. Read all Material Safety Data Sheets (MSDS) and container labels provided with the paints and solvents. Follow the paint and solvents manufacturer's safety instructions.
- Fire extinguisher equipment shall be present and working.
- Sprayer generates sparks. When flammable liquid is used in or near the sprayer or for flushing or cleaning, keep sprayer at least 20 feet (6 m) away from explosive vapors.

**SKIN INJECTION HAZARD**

- Do not aim the gun at, or spray any person or animal.
- Keep hands and other body parts away from the discharge. For example, do not try to stop leaks with any part of the body.
- Always use the nozzle tip guard. Do not spray without nozzle tip guard in place.
- Use Graco nozzle tips.
- Use caution when cleaning and changing nozzle tips. In the case where the nozzle tip clogs while spraying, follow the **Pressure Relief Procedure** for turning off the unit and relieving the pressure before removing the nozzle tip to clean.
- Do not leave the unit energized or under pressure while unattended. When the unit is not in use, turn off the unit and follow the **Pressure Relief Procedure** for turning off the unit.
- High-pressure spray is able to inject toxins into the body and cause serious bodily injury. In the event that injection occurs, **get immediate surgical treatment**.
- Check hoses and parts for signs of damage. Replace any damaged hoses or parts.
- This system is capable of producing 3300 psi. Use Graco replacement parts or accessories that are rated a minimum of 3300 psi.
- Always engage the trigger lock when not spraying. Verify the trigger lock is functioning properly.
- Verify that all connections are secure before operating the unit.

Know how to stop the unit and bleed pressure quickly. Be thoroughly familiar with the controls.

 WARNING	
 	<p>EQUIPMENT MISUSE HAZARD Misuse can cause death or serious injury.</p> <ul style="list-style-type: none"> • Always wear appropriate gloves, eye protection, and a respirator or mask when painting. • Do not operate or spray near children. Keep children away from equipment at all times. • Do not overreach or stand on an unstable support. Keep effective footing and balance at all times. • Stay alert and watch what you are doing. • Do not leave the unit energized or under pressure while unattended. When the unit is not in use, turn off the unit and follow the Pressure Relief Procedure for turning off the unit. • Do not operate the unit when fatigued or under the influence of drugs or alcohol. • Do not kink or over-bend the hose. • Do not expose the hose to temperatures or to pressures in excess of those specified by Graco. • Do not use the hose as a strength member to pull or lift the equipment.
 	<p>ELECTRIC SHOCK HAZARD This equipment must be grounded. Improper grounding, setup, or usage of the system can cause electric shock.</p> <ul style="list-style-type: none"> • Turn off and disconnect power at main switch before disconnecting any cables and before servicing equipment. • Connect only to grounded power source. • All electrical wiring must be done by a qualified electrician and comply with all local codes and regulations.
	<p>PRESSURIZED ALUMINUM PARTS HAZARD Use of fluids that are incompatible with aluminum in pressurized equipment can cause serious chemical reaction and equipment rupture. Failure to follow this warning can result in death, serious injury, or property damage.</p> <ul style="list-style-type: none"> • Do not use 1,1,1-trichloroethane, methylene chloride, other halogenated hydrocarbon solvents or fluids containing such solvents. • Many other fluids may contain chemicals that can react with aluminum. Contact your material supplier for compatibility.
 	<p>MOVING PARTS HAZARD Moving parts can pinch, cut or amputate fingers and other body parts.</p> <ul style="list-style-type: none"> • Keep clear of moving parts. • Do not operate equipment with protective guards or covers removed. • Pressurized equipment can start without warning. Before checking, moving, or servicing equipment, follow the Pressure Relief Procedure and disconnect all power sources.
	<p>PERSONAL PROTECTIVE EQUIPMENT You must wear appropriate protective equipment when operating, servicing, or when in the operating area of the equipment to help protect you from serious injury, including eye injury, hearing loss, inhalation of toxic fumes, and burns. This equipment includes but is not limited to:</p> <ul style="list-style-type: none"> • Protective eyewear, and hearing protection. • Respirators, protective clothing, and gloves as recommended by the fluid and solvent manufacturer.

Component Identification

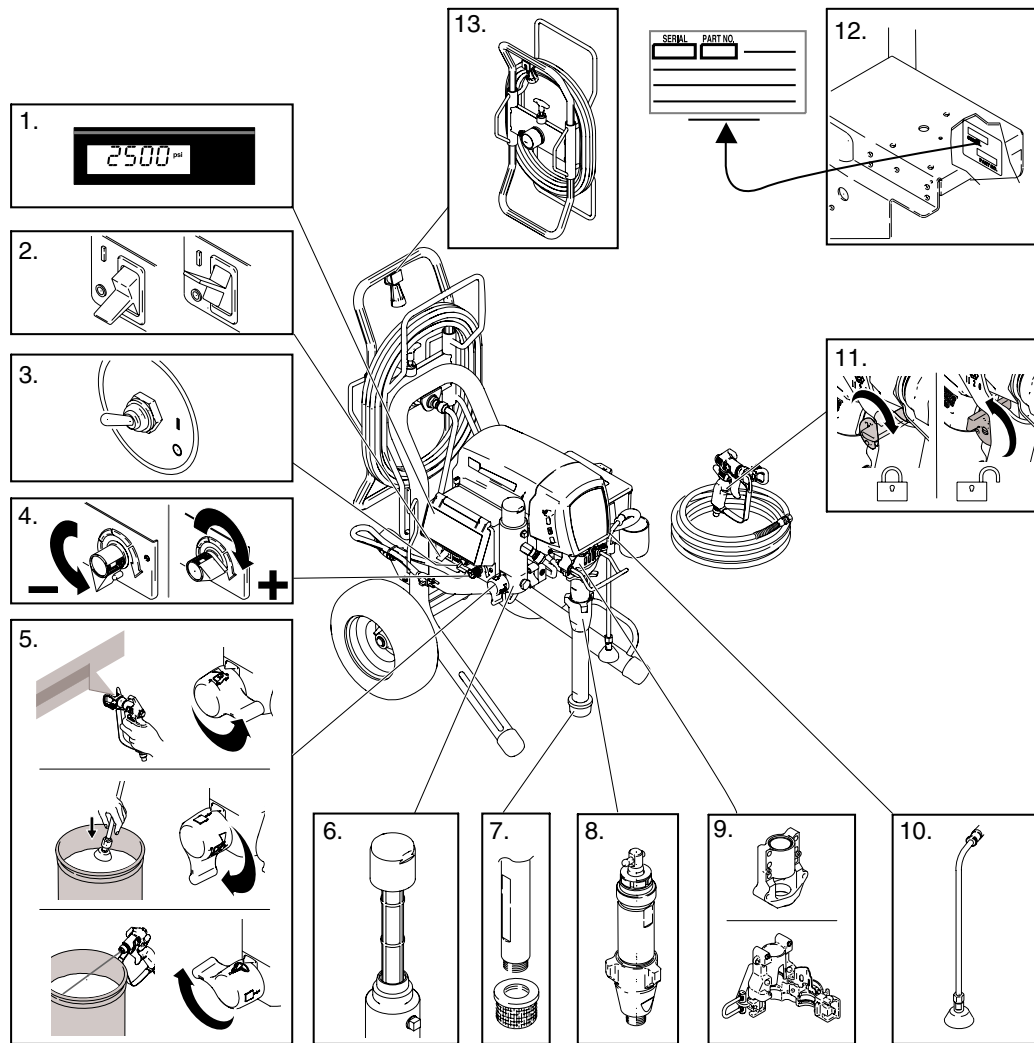

ti14839a

1	Premium Digital Display
2	ON/OFF switch
3	WatchDog™ Switch (not available on Mark V)
4	Pressure Control
5	Prime / Spray Valve
6	Filter
7	Siphon Tube
8	Pump
9	Bearing Housing / ProConnect™
10	Drain Tube
11	Trigger Lock
12	Model/serial tag
13	Hose Reel

Pressure Relief Procedure

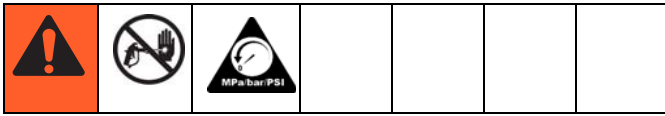

1. Turn power **OFF**. Wait 7 seconds for power to dissipate.

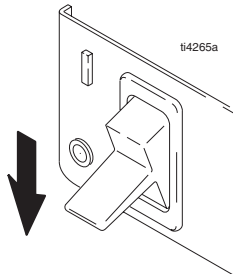

2. Lock gun trigger safety. Remove guard and SwitchTip.

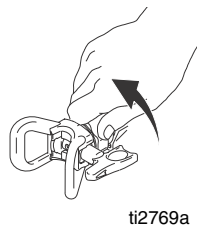
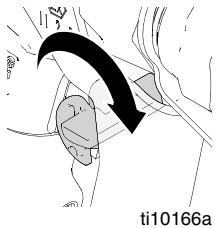

3. Turn pressure to lowest setting. Trigger gun to relieve pressure.



4. Put drain tube in pail. Turn prime valve down to DRAIN position.

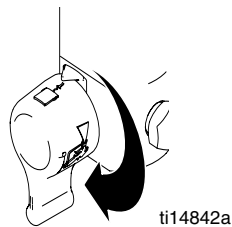
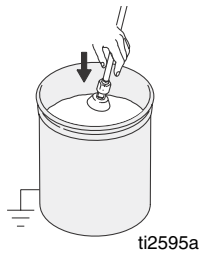

Grounding

The sprayer must be grounded. Grounding reduces the risk of static and electric shock by providing an escape wire for the electrical current due to static build up or in the event of a short circuit.

The sprayer cord includes a grounding wire with an appropriate grounding contact.

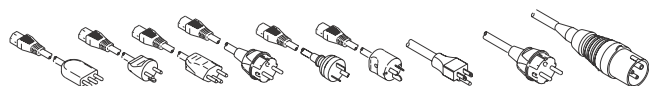

The plug must be plugged into an outlet that is properly installed and grounded in accordance with all local codes and ordinances.

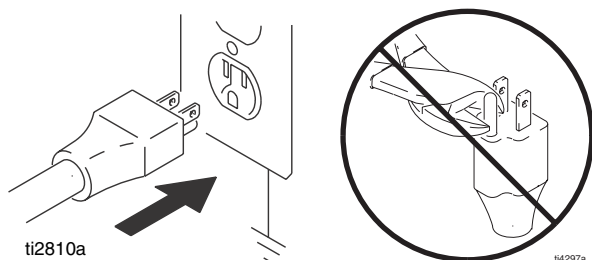

Do not modify plug! Tampering with the plug will result in a voided warranty. If plug will not fit in outlet, have grounded outlet installed by a qualified electrician. Do not use an adapter.

Power Requirements

- 100-120V units require 100-120 VAC, 50/60 Hz, 15A, 1 phase.
- 230V units require 230 VAC, 50/60 HZ, 10A, 1 phase.

Extension Cord

Use an extension cord with an undamaged ground contact. If an extension cord is necessary, use a 3-wire, 12 AWG (2.5 mm²) minimum.

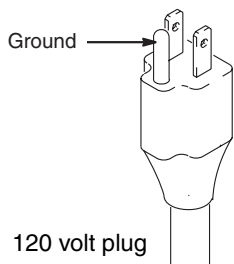

Pails



Solvent and oil/based fluids: follow local code. Use only conductive metal pails, placed on a grounded surface such as concrete.

Do not place pail on a nonconductive surface such as paper or cardboard which interrupts grounding continuity.

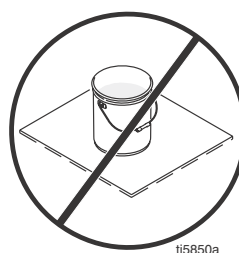

Grounding a metal pail: connect a ground wire to the pail by clamping one end to pail and other end to a true earth ground.

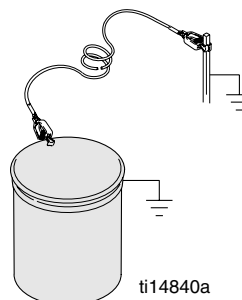

To maintain grounding continuity when flushing or relieving pressure: hold metal part of spray gun firmly to side of a grounded metal pail. Then trigger gun.

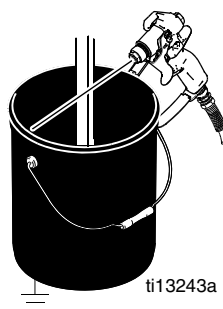

Troubleshooting

Mechanical/Fluid Flow



Perform **Pressure Relief Procedure**; page 8.

TYPE OF PROBLEM	WHAT TO CHECK If check is OK, go to next check	WHAT TO DO When check is not OK, refer to this column
E=XX is displayed	1. Fault condition exists	1. Determine fault correction from table, page 13.
False tripping of WatchDog system. EMPTY is displayed. Pump does not run.	1. Operating conditions out of WatchDog parameters. Pump output is low, see below.	1. Turn pressure down. Refer to operation manual for adjusting. Operate without WatchDog active; see operation manual.

TYPE OF PROBLEM	WHAT TO CHECK If check is OK, go to next check	WHAT TO DO When check is not OK, refer to this column
Pump output is low	1. Spray tip worn	1. Follow Pressure Relief Procedure on page 8, then replace tip. See your separate gun or tip manual.
	2. Spray tip clogged	2. Relieve pressure. Check and clean spray tip.
	3. Paint supply	3. Refill and reprime pump.
	4. Intake strainer clogged	4. Remove and clean, then reinstall
	5. Intake valve ball and piston ball are not seating properly	5. Remove intake valve and clean. Check balls and seats for nicks; replace if necessary; see pump manual 310643 or 310894. Strain paint before using to remove particles that could clog pump.
	6. Suction hose connections	6. Tighten any loose connections. Check for missing or damaged seals.
	7. Fluid filter, tip filter, or tip is clogged or dirty.	7. Clean filter; see operation manual.
	8. Prime valve leaking	8. Relieve pressure. Repair prime valve.
	9. Verify pump does not continue to stroke when gun trigger is released. (Prime valve not leaking.)	9. Service pump; see pump manual 310643 or 310894.
	10. Leaking around throat packing nut which may indicate worn or damaged packings.	10. Replace packings; see pump manual. Also check piston valve seat for hardened paint or nicks and replace if necessary. Tighten packing nut/wet-cup.
	11. Pump rod damage	11. Repair pump. See pump manual 310643 or 310894.
	12. Low stall pressure	12. Turn pressure knob fully clockwise. Make sure pressure control knob is properly installed to allow full clockwise position. If problem persists, replace pressure transducer.
	13. Piston packings are worn or damaged	13. Replace packings; see pump manual 310643 or 310894.
	14. O-ring in pump is worn or damaged	14. Replace o-ring; see pump manual 310643 or 310894.
	15. Intake valve ball is packed with material	15. Clean intake valve; see pump manual 310643 or 310894.
	16. Pressure setting is too low	16. Increase pressure; see pump manual 310643 or 310894.
	17. Large pressure drop in hose with heavy materials	17. Use larger diameter hose and/or reduce overall length of hose. Use of more than 100 ft of 1/4 in. hose significantly reduces performance of sprayer. Use 3/8 in. hose for optimum performance (50 ft minimum).

TYPE OF PROBLEM	WHAT TO CHECK If check is OK, go to next check	WHAT TO DO When check is not OK, refer to this column
Motor runs but pump does not stroke	1. Displacement pump pin (32) damaged or missing; see pump manual 310643 or 310894.	1. Replace pump pin if missing. Be sure retainer spring (31) is fully in groove all around connecting rod; see pump manual 310643 or 310894.
	2. Connecting rod assembly (43) damaged; see pump manual 310643 or 310894.	2. Replace connecting rod assembly; see pump manual 310643 or 310894.
	3. Gears or drive housing damaged, page 28.	3. Inspect drive housing assembly and gears for damage and replace if necessary; see pump manual 310643 or 310894.
Excessive paint leakage into throat packing nut	1. Throat packing nut is loose	1. Remove throat packing nut spacer. Tighten throat packing nut just enough to stop leakage.
	2. Throat packings are worn or damaged	2. Replace packings; see pump manual 310643 or 310894.
	3. Displacement rod is worn or damaged	3. Replace rod; see pump manual 310643 or 310894.
Fluid is spitting from gun	1. Air in pump or hose	1. Check and tighten all fluid connections. Cycle pump as slowly as possible during priming.
	2. Tip is partially clogged	2. Clear tip; see tip guard manual 309640.
	3. Fluid supply is low or empty	3. Refill fluid supply. Prime pump; see pump manual 310643 or 310894. Check fluid supply often to prevent running pump dry.
Pump is difficult to prime	1. Air in pump or hose	1. Check and tighten all fluid connections. Cycle pump as slowly as possible during priming.
	2. Intake valve is leaking	2. Clean intake valve. Be sure ball seat is not nicked or worn and that ball seats well. Reassemble valve.
	3. Pump packings are worn	3. Replace pump packings; see pump manual 310643 or 310894.
	4. Paint is too thick	4. Thin the paint according to supplier recommendations.
No display, sprayer operates	1. Display is damaged or has bad connection	1. Check connections. Replace display.

Electrical

Symptom: Sprayer does not run or stops running.

Perform **Pressure Relief Procedure**; page 8.

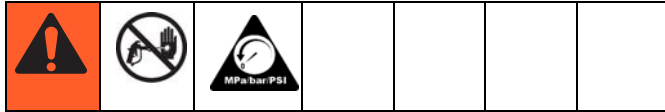

--	--	--	--	--	--	--

To avoid electrical shock or moving parts hazards when covers are removed for troubleshooting, wait 30 seconds after unplugging power cord for stored electricity to dissipate. Keep clear of electrical and moving parts during troubleshooting procedures.

- Plug sprayer into correct voltage, grounded outlet
- Set power switch OFF for 30 seconds and then ON again (this ensures sprayer is in normal run mode).
- Turn pressure control knob clockwise 1/2 turn
- View digital display

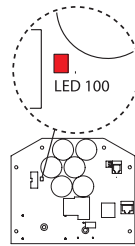



If no digital display is available, use control board status light to troubleshoot problems: Turn ON/OFF switch OFF, remove control cover and then turn power back ON. Observe status light. Blinking LED total count equals digital error code i.e., two blinks equals E=02.

TYPE OF PROBLEM	WHAT TO CHECK	HOW TO CHECK
Sprayer does not run at all	See flow chart, page 19.	
Digital display is blank		
Control board status light never lights		
Sprayer does not run at all	Check transducer or transducer connections	<ol style="list-style-type: none"> 1. Make sure there is no pressure in the system (see Pressure Relief Procedure, page 8). Check fluid path for clogs, such as clogged filter. 2. Use airless paint spray hose with no metal braid 1/4 in. x 50 ft minimum. Smaller hose or metal braid hose may result in high-pressure spikes. 3. Set sprayer to OFF and disconnect power to sprayer. 4. Check transducer and connections to control board. 5. Disconnect transducer from control board socket. Check that transducer and control board contacts are clean and secure. 6. Reconnect transducer to control board socket. Connect power, set sprayer ON and control knob 1/2 turn clockwise. If sprayer does not run properly, set sprayer to OFF and go to next step. 7. Install new transducer. Connect power, set sprayer ON and control knob 1/2 turn clockwise. Replace control board if sprayer does not run properly.
Digital display shows E=02		
Control board status light blinks 2 times repeatedly		

E=02

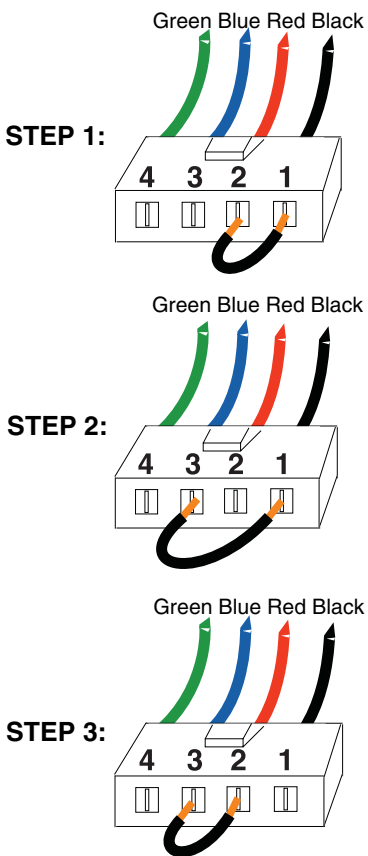
TYPE OF PROBLEM	WHAT TO CHECK	HOW TO CHECK
Sprayer does not run at all Digital display shows E=03 	Check transducer or transducer connections (control board is not detecting a pressure signal).	<ol style="list-style-type: none"> 1. Set sprayer to OFF and disconnect power to sprayer. 2. Check transducer and connections to control board. 3. Disconnect transducer from control board socket. Check to see if transducer and control board contacts are clean and secure.
Control board status light blinks 3 times repeatedly		<ol style="list-style-type: none"> 4. Reconnect transducer to control board socket. Connect power, set sprayer ON and control knob to 1/2 turn clockwise. If sprayer does not run, set sprayer to OFF and go to next step. 5. Connect a confirmed working transducer to control board socket. 6. Set sprayer ON and control knob to 1/2 turn clockwise. If sprayer runs, install new transducer. Replace control board if sprayer does not run. 7. Check transducer resistance with ohmmeter (less than 9k ohm between red and black wires and 3-6k ohm between green and yellow wires).

TYPE OF PROBLEM	WHAT TO CHECK	HOW TO CHECK
Sprayer does not run at all Digital display shows E=05 	Control is commanding motor to run but motor shaft does not rotate. Possibly locked rotor condition, an open connection exists between motor and control, there is a problem with motor or control board, or motor amp draw is excessive.	<ol style="list-style-type: none"> 1. Remove pump and try to run sprayer. If motor runs, check for locked or frozen pump or drive train. If sprayer does not run, continue to step 2. 2. Set sprayer to OFF and disconnect power to sprayer. 3. Disconnect motor connector(s) from control board socket(s). Check that motor connector and control board contacts are clean and secure. If contacts are clean and secure, continue to step 4. 4. Set sprayer to OFF and spin motor fan 1/2 turn. Restart sprayer. If sprayer runs, replace control board. If sprayer does not run, continue to step 5. 5. Perform Spin Test: Test at large 4-pin motor field connector. Disconnect fluid pump from sprayer. Test motor by placing a jumper across pins 1 & 2. Rotate motor fan at about 2 revolutions per second. A cogging resistance to motion should be felt at the fan. The motor should be replaced if no resistance is felt. Repeat for pin combinations 1 & 3 and 2 & 3. Pin 4 (the green wire) is not used in this test. If all spin test is positive, continue to step 6.
Control board status light blinks 5 times repeatedly		 <p>The diagram illustrates the 'Perform Spin Test' procedure in three steps. Each step shows a 4-pin connector with pins labeled 4, 3, 2, and 1 from left to right. Wires are color-coded: Green for pin 4, Blue for pin 3, Red for pin 2, and Black for pin 1.</p> <ul style="list-style-type: none"> STEP 1: A black wire (pin 1) is connected to a red wire (pin 2). STEP 2: A black wire (pin 1) is connected to a blue wire (pin 3). STEP 3: A black wire (pin 1) is connected to a red wire (pin 2).

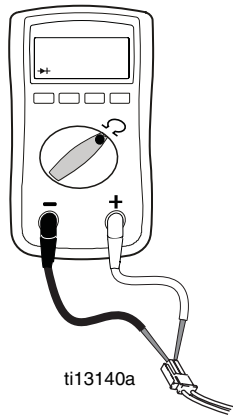
TYPE OF PROBLEM	WHAT TO CHECK	HOW TO CHECK																
Sprayer does not run at all Digital display shows E=05 	Control is commanding motor to run but motor shaft does not rotate. Possibly locked rotor condition, an open connection exists between motor and control, there is a problem with motor or control board, or motor amp draw is excessive.	6. Perform Field Short Test: Test at large 4-pin motor field connector. There should not be continuity from pin 4, the ground wire, and any of the remaining 3 pins. If motor field connector tests fail, replace motor. 7. Check Motor Thermal Switch: Unplug thermal wires. Set meter to ohms. Meter should read the proper resistance for each model (see table below).																
Control board status light blinks 5 times repeatedly		 <table border="1" data-bbox="950 989 1302 1339"> <thead> <tr> <th colspan="2">Resistance Table:</th> </tr> </thead> <tbody> <tr> <td>695</td> <td>0 ohms</td> </tr> <tr> <td>795</td> <td>2k ohms</td> </tr> <tr> <td>1095</td> <td>3.9k ohms</td> </tr> <tr> <td>1595</td> <td>6.2k ohms</td> </tr> <tr> <td>MARK IV</td> <td>2k ohms</td> </tr> <tr> <td>MARK V 120V</td> <td>6.2k ohms</td> </tr> <tr> <td>MARK V 240V</td> <td>3.9k ohms</td> </tr> </tbody> </table>	Resistance Table:		695	0 ohms	795	2k ohms	1095	3.9k ohms	1595	6.2k ohms	MARK IV	2k ohms	MARK V 120V	6.2k ohms	MARK V 240V	3.9k ohms
Resistance Table:																		
695	0 ohms																	
795	2k ohms																	
1095	3.9k ohms																	
1595	6.2k ohms																	
MARK IV	2k ohms																	
MARK V 120V	6.2k ohms																	
MARK V 240V	3.9k ohms																	

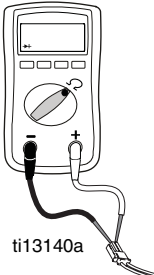
TYPE OF PROBLEM	WHAT TO CHECK	HOW TO CHECK																
<p>Sprayer does not run at all</p> <p>Digital display shows E=06</p> <p style="text-align: center; font-size: 2em;">E=06</p> <p>Control board status light blinks 6 times repeatedly</p>	<p>Allow sprayer to cool. If sprayer runs when cool, correct cause of overheating. Keep sprayer in cooler location with good ventilation. Make sure motor air intake is not blocked. If sprayer still does not run, follow Step 1.</p>	<p>NOTE: Motor must be cooled down for the test.</p> <ol style="list-style-type: none"> 1. Check thermal device connector (yellow wires) at control board. 2. Disconnect thermal device connector from control board socket. Make sure contacts are clean and secure. <p>Measure resistance of the thermal device. If reading is not correct, replace motor.</p> <p>Check Motor Thermal Switch: Unplug thermal wires. Set meter to ohms. Meter should read the proper resistance for each model (see table below).</p> <div style="display: flex; align-items: center; justify-content: center;">  <table border="1" data-bbox="1149 898 1507 1243" style="margin-left: 20px;"> <thead> <tr> <th colspan="2">Resistance Table:</th> </tr> </thead> <tbody> <tr> <td>695</td> <td>0 ohms</td> </tr> <tr> <td>795</td> <td>2k ohms</td> </tr> <tr> <td>1095</td> <td>3.9k ohms</td> </tr> <tr> <td>1595</td> <td>6.2k ohms</td> </tr> <tr> <td>MARK IV</td> <td>2k ohms</td> </tr> <tr> <td>MARK V 120V</td> <td>6.2k ohms</td> </tr> <tr> <td>MARK V 240V</td> <td>3.9k ohms</td> </tr> </tbody> </table> </div> <ol style="list-style-type: none"> 3. Reconnect thermal device connector to control board socket. Connect power, turn sprayer ON and control knob 1/2 turn clockwise. If sprayer does not run, replace control board. 	Resistance Table:		695	0 ohms	795	2k ohms	1095	3.9k ohms	1595	6.2k ohms	MARK IV	2k ohms	MARK V 120V	6.2k ohms	MARK V 240V	3.9k ohms
Resistance Table:																		
695	0 ohms																	
795	2k ohms																	
1095	3.9k ohms																	
1595	6.2k ohms																	
MARK IV	2k ohms																	
MARK V 120V	6.2k ohms																	
MARK V 240V	3.9k ohms																	
<p>Sprayer does not run at all</p> <p>Digital display shows E=09</p> <p style="text-align: center; font-size: 2em;">E=09</p> <p>Control board status light blinks 9 times repeatedly</p>	<p>Check the connections. Control is not receiving a motor position sensor signal</p>	<ol style="list-style-type: none"> 1. Turn power OFF. 2. Disconnect motor position sensor and inspect for damage at connectors. 3. Reconnect sensor. 4. Turn power ON. If error continues, replace motor. 																

TYPE OF PROBLEM	WHAT TO CHECK	HOW TO CHECK
Sprayer does not run at all	Check to see if control board is over heating.	<ol style="list-style-type: none"> 1. Make sure motor air intake is not blocked. 2. Make sure fan has not failed. 3. Make sure control board is properly connected to back plate and that conductive thermal paste is used on power components. 4. Replace control board. 5. Replace motor.
Digital display shows E=10		
		
Control board status light blinks 10 times repeatedly		

Sprayer Will Not Shut Off

1. Perform **Pressure Relief Procedure**; page 8. Leave prime valve open and power switch OFF.
2. Remove control box cover so the control board status light can be viewed if available.

Troubleshooting Procedure

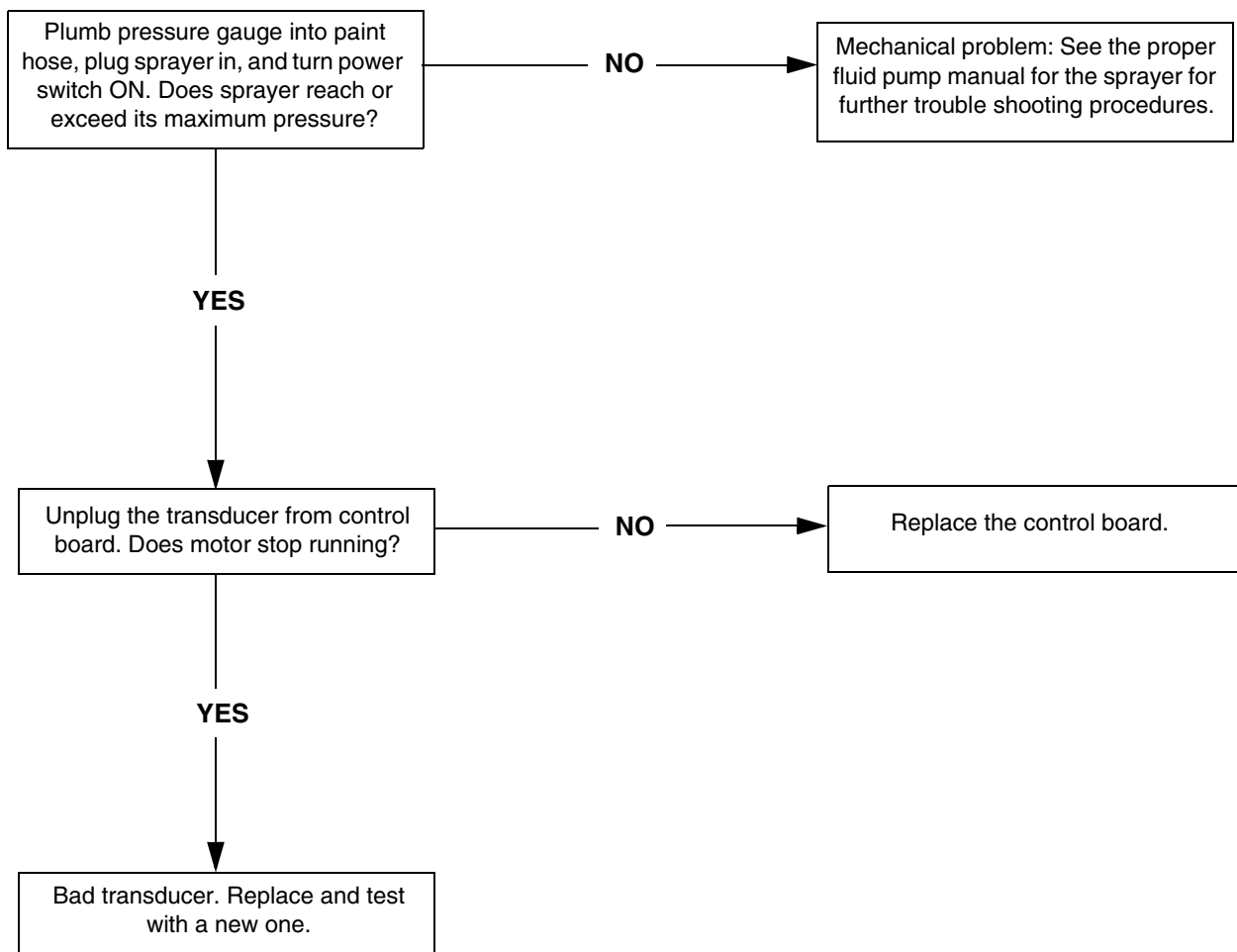

Sprayer Will Not Run
(See following page for steps)

Remove control box cover. Turn sprayer ON. Observe control board status light on control board (see page 13).	
No light	
Once	Normal operation
Light on Continuously	Control board commanding motor to run
Flashing	See Error Code section for further troubleshooting

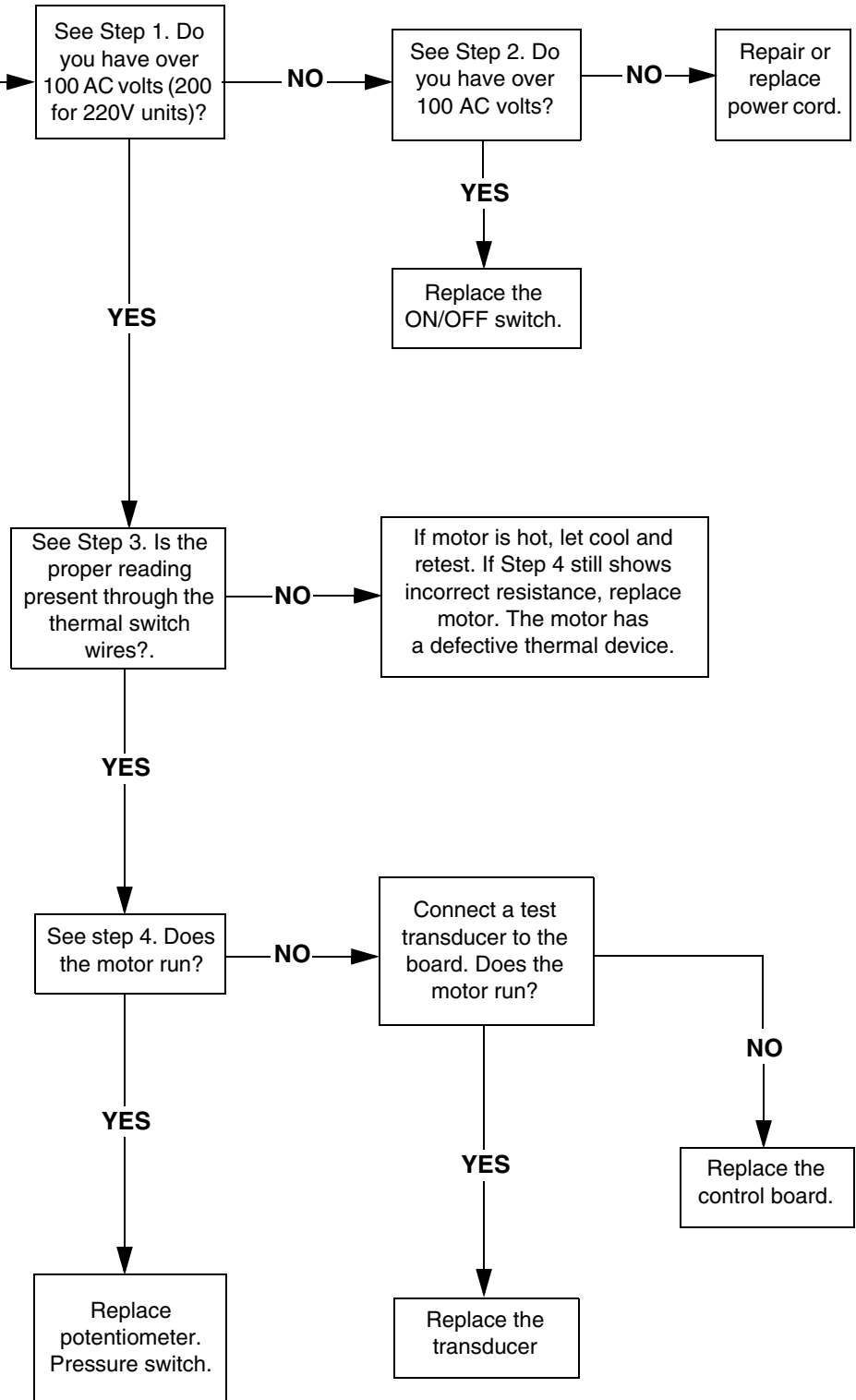

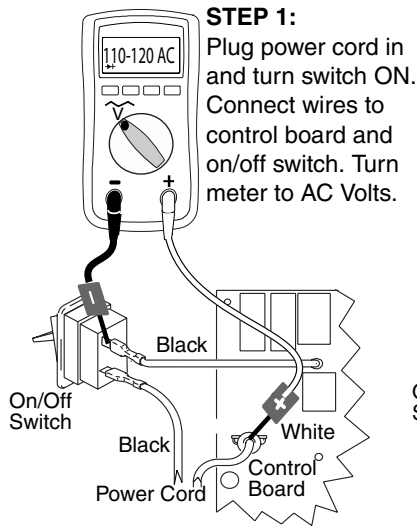

STEP 1:
Plug power cord in and turn switch ON. Connect wires to control board and on/off switch. Turn meter to AC Volts.

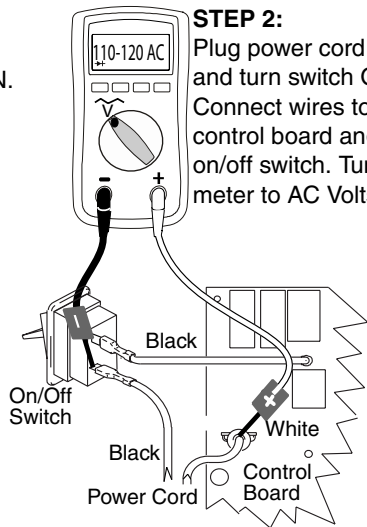

STEP 2:
Plug power cord in and turn switch ON. Connect wires to control board and on/off switch. Turn meter to AC Volts.

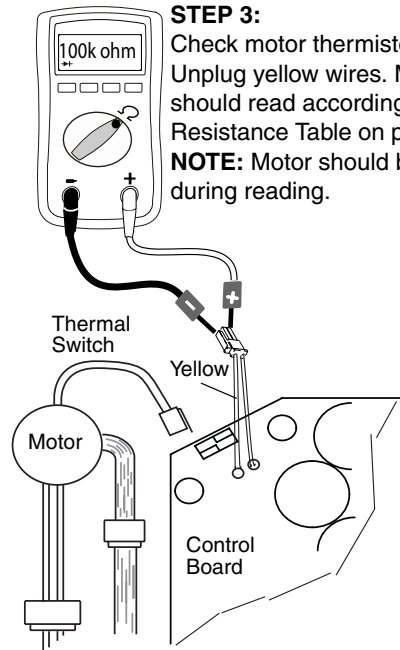

STEP 3:
Check motor thermistor. Unplug yellow wires. Meter should read according to Resistance Table on page 17. **NOTE:** Motor should be cool during reading.

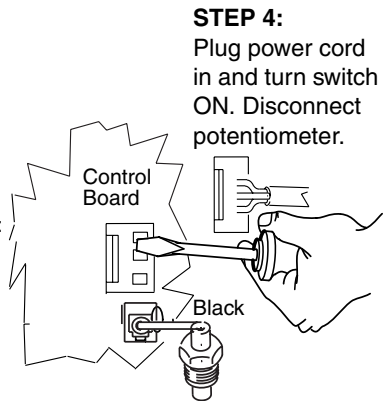
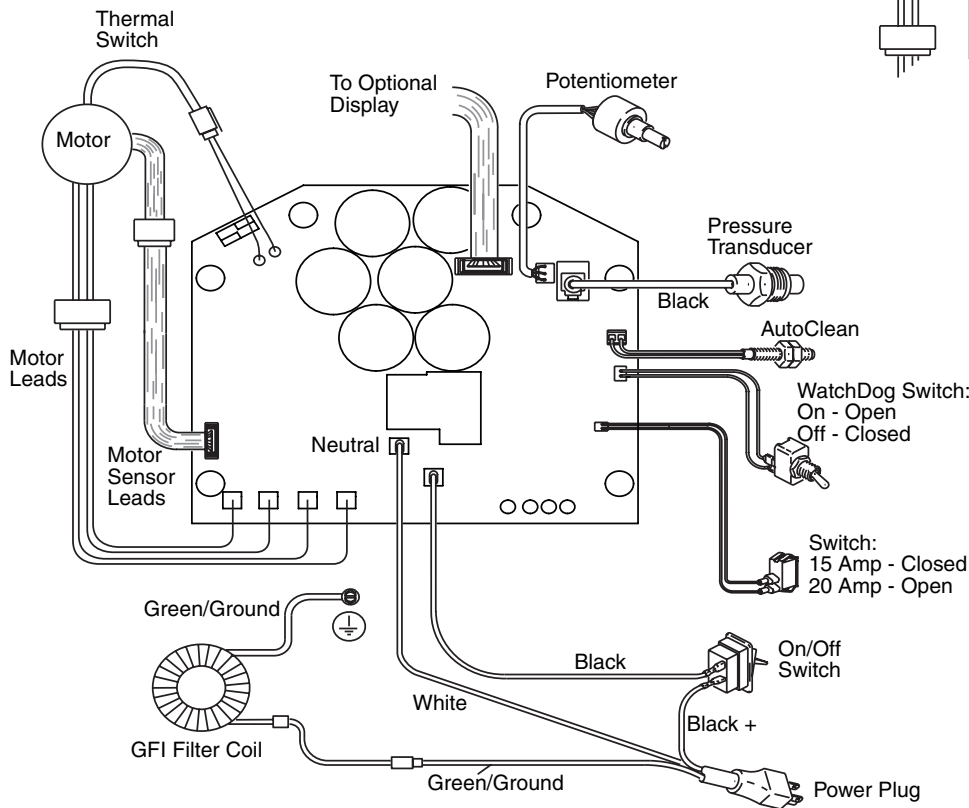

STEP 4:
Plug power cord in and turn switch ON. Disconnect potentiometer.

240 VAC and 110 VAC Motor Control Board

Removal



Perform **Pressure Relief Procedure**; page 8. Wait 5 minutes before servicing.

1. Remove **Motor Shroud** (for units equipped with Hose Reel only):
 - a. Remove bolts from motor shroud.
 - b. Remove pressure tube from sprayer.
 - c. Remove bottom screw from toolbox.
 - d. Loosen (but do not remove) four nuts on shelf. Carefully slide shelf forward.
 - e. Remove shroud.
 - f. Slide shelf back and tighten four nuts on shelf.
2. Remove all four screws (38) and cover (96).
3. Disconnect display connector (A) from motor control board (52).
4. Remove bottom two screws (39). disconnect potentiometer connector (C) from motor control board (52). Disconnect power cord connectors (D) and filter board connectors (J) from ON/OFF switch (33) and remove control panel (68).
5. Disconnect WatchDog switch connector (X) and reed switch connector (L) from motor control board.
6. Disconnect motor control board power connectors (K) from filter board (146).
7. Remove top two screws (39) and control box (61).
8. Disconnect transducer connector (E) from motor control board.
9. Disconnect motor connectors (F, G and H).
10. Remove six screws (27), two screws (102) and control board.

Installation

1. Use acetone or equivalent cleaner to thoroughly remove thermal paste from pockets on powerbar.

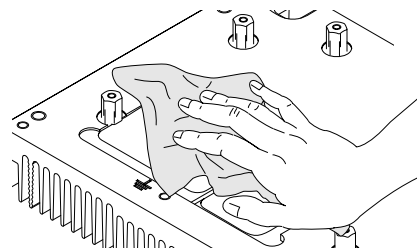

ti14695a

2. Apply new thermal paste into both pockets of powerbar.

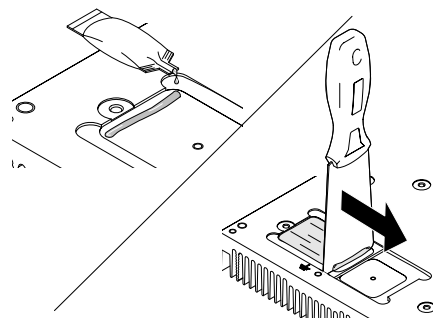

ti14693a

3. Replace two inner screws to control board and torque to 17 in-lb (1 N•m).

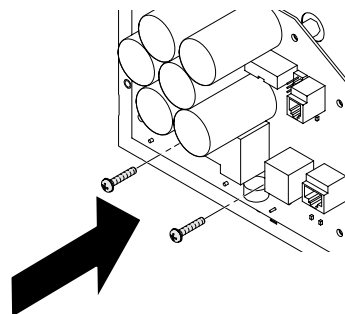

ti14696a

4. Replace six outer screws to control board and torque to 11 in-lb (1.25 N•m).

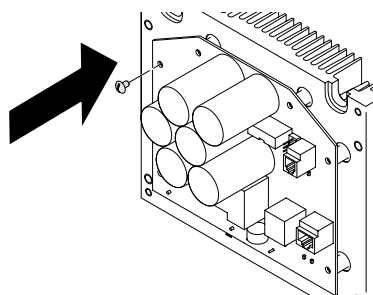

ti14697a

5. Make switch dip switch is moved to the left (toward inside of board). See **Wiring Diagram**, page 40.
6. Connect motor connectors (F, G and H) and install into baffle.
7. Connect transducer connector (E) to motor control board.
8. Connect motor control board power connectors (K) to filter board (146).
9. Install control box (61) with top two screws (39).
10. Connect filter board power connectors (J) and power cord connectors (D) to ON/OFF switch (33).
11. Connect potentiometer connector (C) to motor control board.
12. Connect WatchDog switch (X) and reed switch connector (L) to motor control board.
13. Install control panel (68) with two screws (39).
14. Connect display connector (A) to motor control board (52).
15. Install cover (96) with four screws (38)
16. Install **Motor Shroud** (for units equipped with Hose Reel only):
 - a. Loosen (but do not remove) four nuts on shelf and slide shelf forward.
 - b. Replace shroud.
 - c. Slide shelf back and tighten four nuts on shelf.
 - d. Replace bottom screw from toolbox and tighten.
 - e. Replace pressure tube from sprayer.
 - f. Replace bolts from motor shroud.

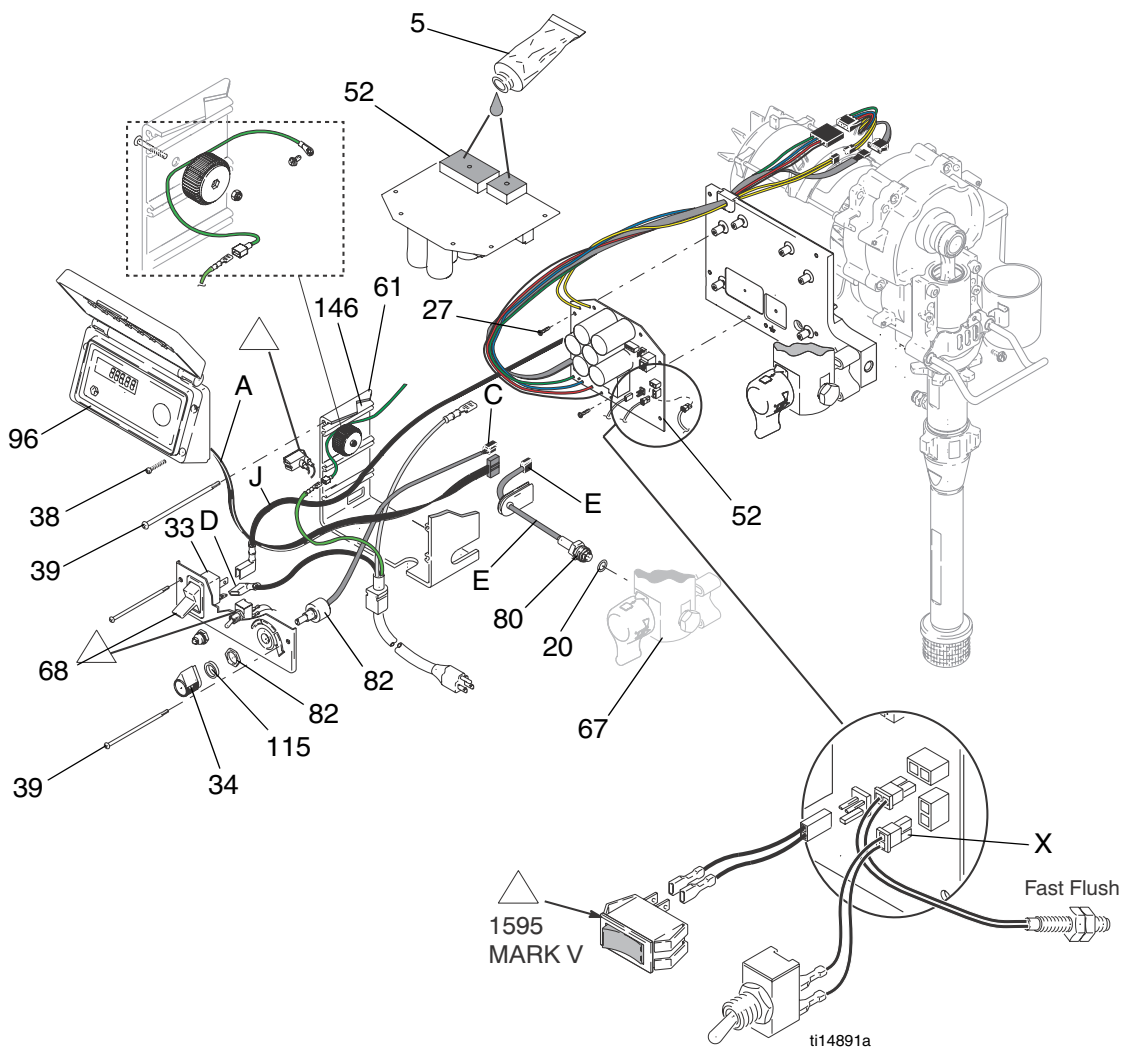

240 VAC Filter Board



Perform **Pressure Relief Procedure**; page 8.

Removal

1. Remove four screws (38) and cover (96).
2. Disconnect display connector (A) from motor control board (52).
3. Remove bottom two screws (39). disconnect potentiometer connector (C) from motor control board (52). Disconnect power cord connectors (D) and filter board connectors (J) from ON/OFF switch (33) and remove control panel (68).
4. Disconnect WatchDog switch connector (X) and reed switch connector (L) from motor control board.
5. Disconnect motor control board power connectors (K) from filter board (146).

6. Remove four screws (163) from filter board (146).

Installation

1. Install filter board (146) with four screws (163).
2. Connect motor control board power connectors (K) to filter board (146).
3. Connect filter board power connectors (J) to top two terminals of ON/OFF switch (33) and power cord connectors (D) to bottom two terminals of ON/OFF switch.
4. Connect potentiometer connector (C) to motor control board (52).
5. Connect WatchDog switch (X) and reed switch connector (L) to motor control board.
6. Install control panel (68) with two screws (39).
7. Connect display connector (A) to motor control board (52).
8. Install cover (96) with four screws (38).

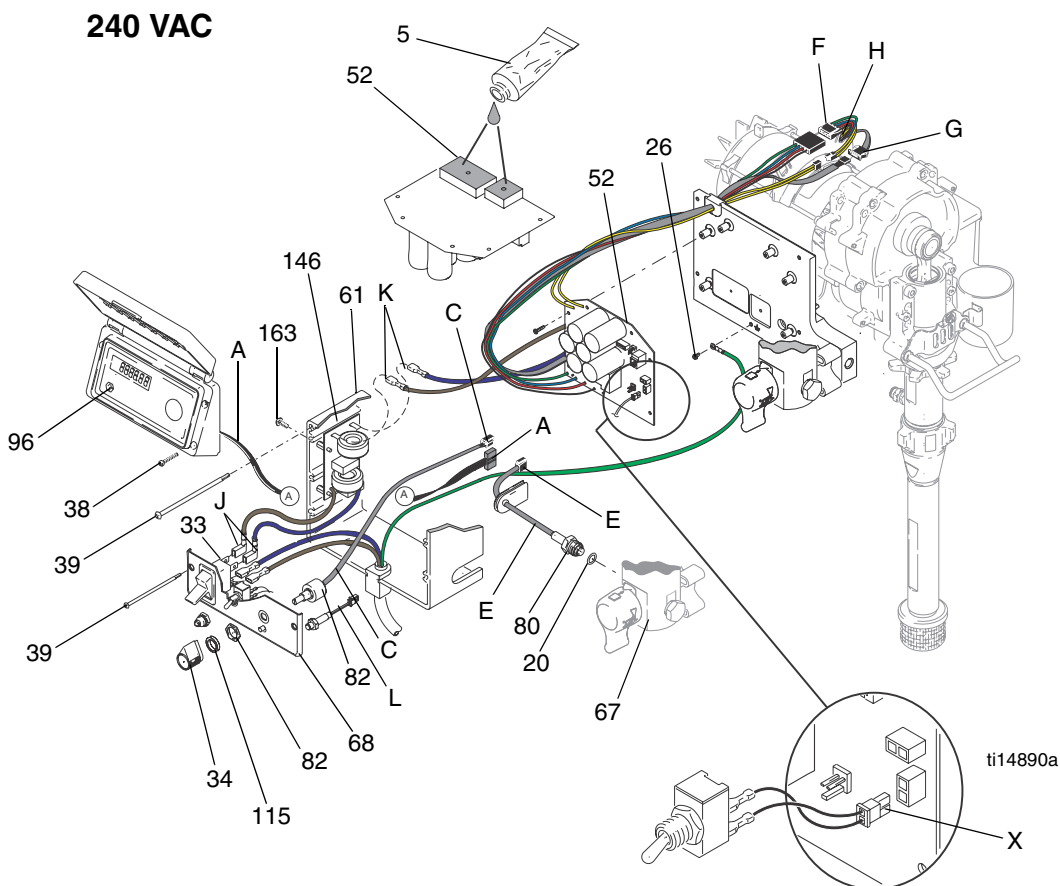

Pressure Adjust Potentiometer

Removal



Perform **Pressure Relief Procedure**; page 8. Wait 5 minutes before servicing.

1. Remove four screws (38) and cover (96).

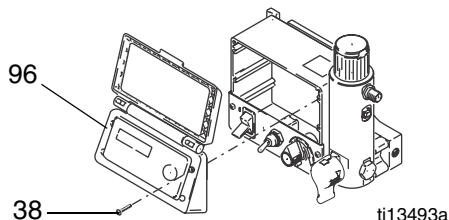

2. Remove two screws and control panel.

3. Disconnect potentiometer connector (C) from motor control board (95).

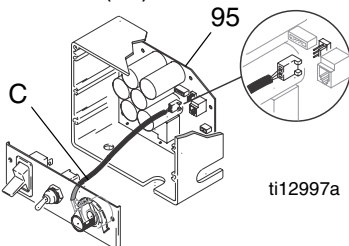

4. Use allen wrench to loosen two screws on knob (34).

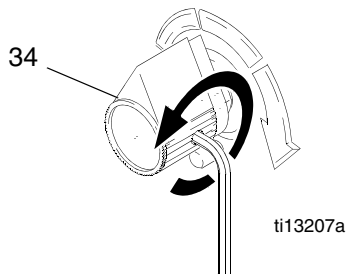

5. Remove gasket (115), nut and potentiometer (82) from control panel (68).

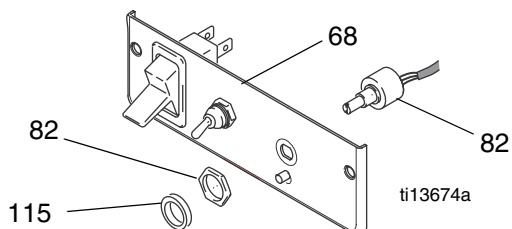

Installation

1. Install gasket (115), nut and potentiometer (82) on control panel (68). Torque nut to 30-35 in-lb (3.25 - 4.0 N•m).

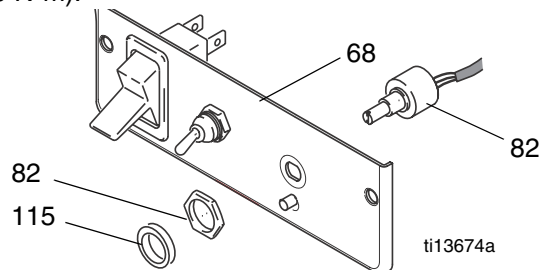

2. Rotate new potentiometer shaft to highest pressure setting (fully clockwise) and install knob (34). Use allen wrench to tighten two screws on knob.

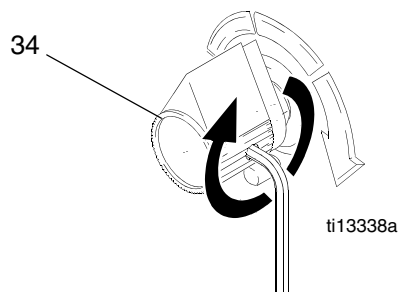

3. Connect potentiometer connector (C) to motor control board.

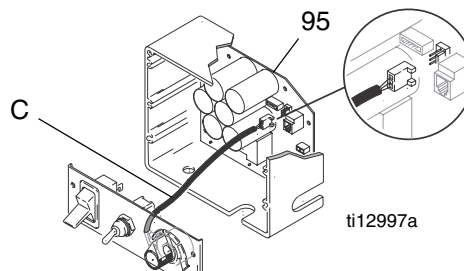

4. Install control panel and tighten two screws.

5. Install cover (96) with four screws (38).

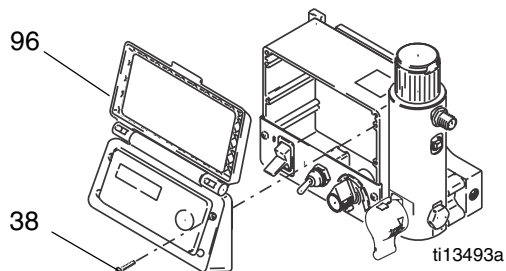

Pressure Control Transducer

Removal



Perform **Pressure Relief Procedure**; page 8. Wait 5 minutes before servicing.

1. Remove four screws (38) and cover (96).

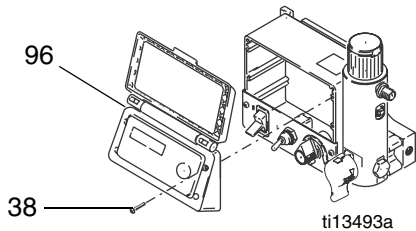

2. Disconnect transducer connector (E) from motor control board (95).

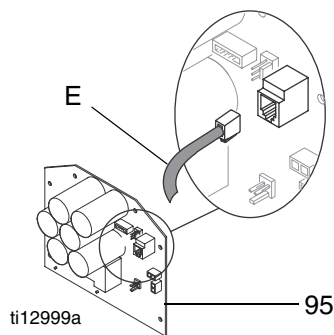

3. Disconnect potentiometer connector (C), WatchDog switch, and reed switch connector from motor control board.

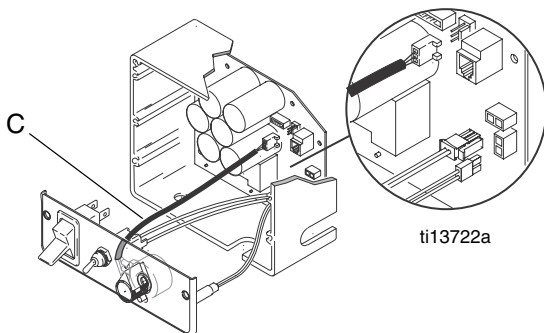

4. Remove four screws (39) and control box (61). Allow control panel (68) to hang down freely.

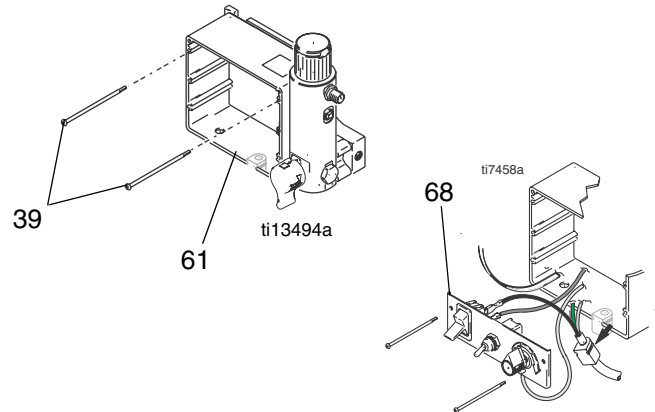

5. Remove grommet (40) from control box then remove transducer (86) and o-ring (20) from filter base (67).

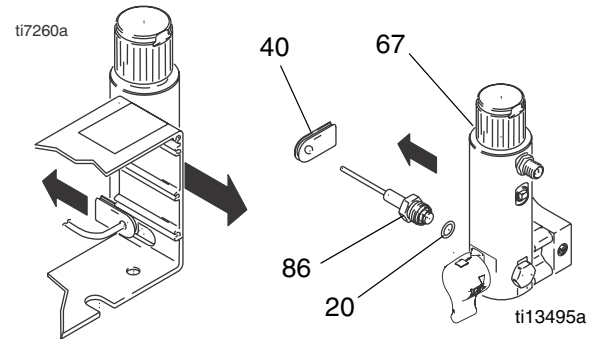

6. Remove grommet (40) from transducer and save for reuse.

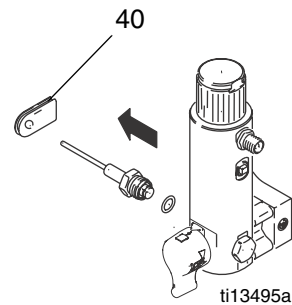

Installation

1. Install o-ring (20) and transducer (86) in filter base (67). Torque to 35-45 ft-lb (47-61 N•m). Install grommet onto transducer (86) and transducer into control box.

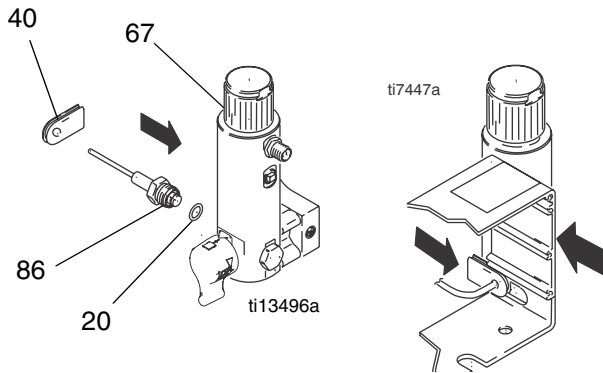

2. Connect transducer connector (E), WatchDog switch, and reed switch connector to control board (95).

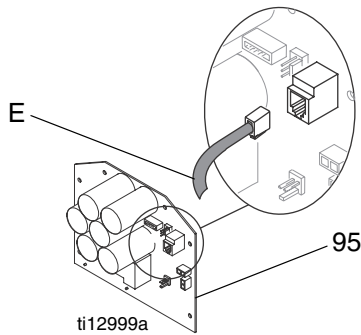

3. Install control box (61) and control panel (68) with four screws (39).

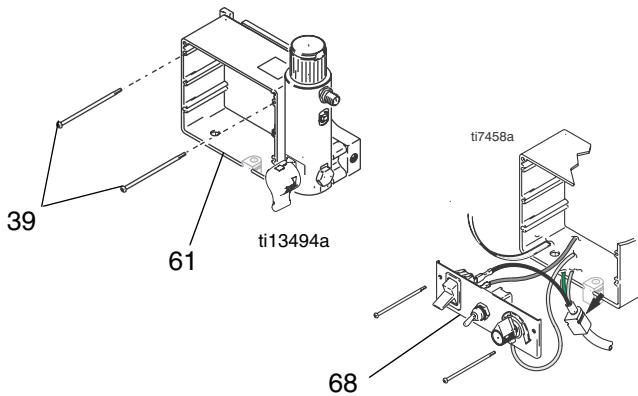

4. Connect potentiometer connector (C), WatchDog switch, and reed switch connector to control board.

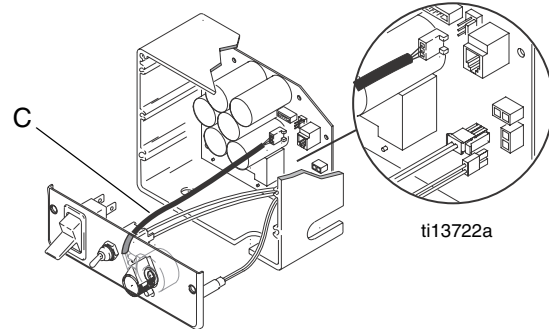

5. Install cover (96) with four screws (38).

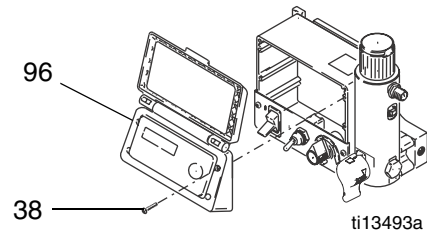

Drive and Bearing Housing Replacement

NOTICE

Do not drop gear cluster (89) when removing drive housing (90). Gear cluster may stay engaged in motor front end bell or drive housing.

Disassembly



Perform **Pressure Relief Procedure**; page 8.

1. Remove screw (31), two nuts (24), pail hanger (55) and pump rod cover (108).
2. Remove pump (91); see **Displacement Pump Replacement**, page 32 (695/795) page 34 (1095/1595/Mark V).

3. Remove two screws (158) and shroud (72).
4. Remove four screws (31) and front cover (51).
5. Remove four screws (14) and washers (12) to remove bearing housing (83) and connecting rod (85).
6. Remove five screws (6) and pull drive housing (90) off motor (84).

Assembly

Make sure gear (89) and thrust washers (28, 30, 90a, 36; see page 29) are in place. Brush grease onto gear teeth.

1. Push drive housing (90) onto motor (84) and install with five screws (6). Torque to 190-210 in-lb (21-23 N•m).
2. Install bearing housing (83) with four screws (14) and washers (12). Torque to 25-30 ft-lb (34-40 N•m).
3. Install front cover (51) with four screws (31).
4. Install shroud (72) with two screws (158).
5. Install pump (91); see **Displacement Pump Replacement**, page 32 (695/795) page 34 (1095/1595/Mark V).
6. Install pump rod cover (108) and pail hanger (55) with screw (31) and two nuts (24).

Drive and Bearing Housing Replacement

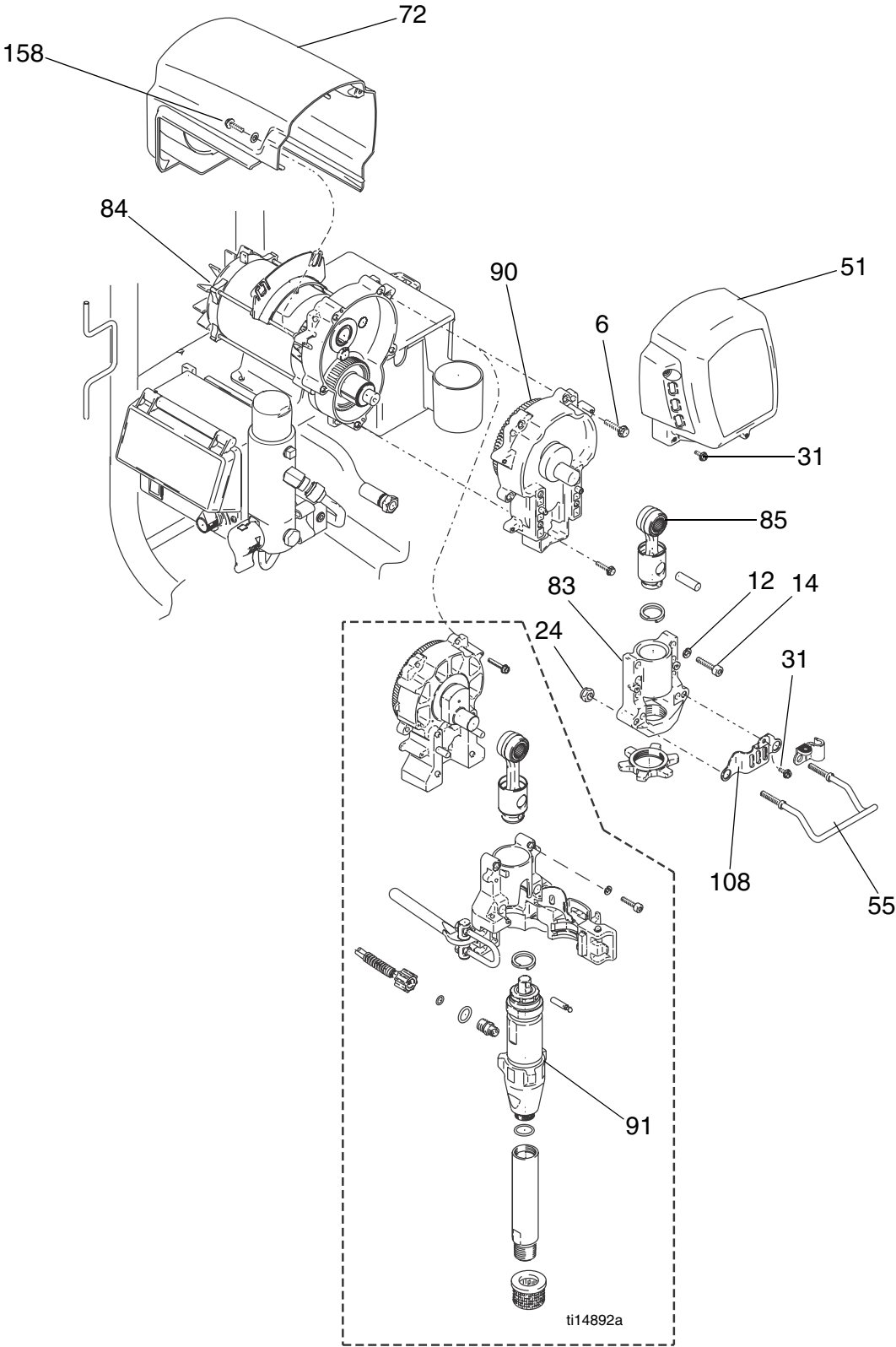

Motor Replacement

Removal



Perform **Pressure Relief Procedure**; page 8.

1. Remove pump (91); see **Displacement Pump Replacement**, page 32 (695/795) page 34 (1095/1595/Mark V).

NOTICE

Do not drop gear cluster (89) when removing drive housing (90). Gear cluster may stay engaged in motor front end bell or drive housing.

2. Remove drive housing (90); see **Drive Housing Replacement**, page 28.
 1. Remove **Motor Shroud**:
 - a. Remove bolts from motor shroud.
 - b. Remove pressure tube from sprayer.
 - c. Remove bottom screw from toolbox.
 - d. Loosen (but do not remove) four nuts on shelf. Carefully slide shelf forward.
 - e. Remove shroud.
 2. Slide shelf back and tighten four nuts on shelf.
 3. Remove four screws (38) and control cover (96).
 4. Remove bottom two screws (39) and allow control panel (68) to hang down freely.
 5. Disconnect all three motor connectors from motor.
 6. Remove top two screws (39) and control housing (61).
 7. Remove strain relief (29) from motor wires and power bar plate (69).
 8. Remove motor wires from baffle 278075 and remove baffle.

9. Remove two screws (23) and nuts (19) on side opposite control.
10. Loosen two nuts (19) on side near control and remove motor (84) from cart frame (62).

Installation

1. Slide new motor (84) under two screws (23) in cart frame (62) near control.
2. Install two screws (23) and nuts (19) on motor side opposite control.
3. Install baffle and connect motor wires.
4. Tighten all four screws (23) and nuts (19). torque nuts to 115-135 in-lb (13-15 N•m).
5. Install strain relief (29) onto motor wires and into power bar plate (69).
6. Install control housing (61) with top two screws (39).
7. Connect all three motor connectors to motor.
8. Install control panel (68) with two screws (39).
9. Install control cover (96) with four screws (38).
10. Install drive housing (90); see **Drive Housing Replacement**, page 28.
11. Install pump (91); see **Displacement Pump Replacement**, page 32 (695/795) page 34 (1095/1595/Mark V).
12. Install **Motor Shroud**.
 - a. Loosen (but do not remove) four nuts on shelf and slide shelf forward.
 - b. Replace shroud.
 - c. Slide shelf back and tighten four nuts on shelf.
 - d. Replace bottom screw from toolbox and tighten.
 - e. Replace pressure tube from sprayer.
 - f. Replace bolts from motor shroud.

Motor Replacement

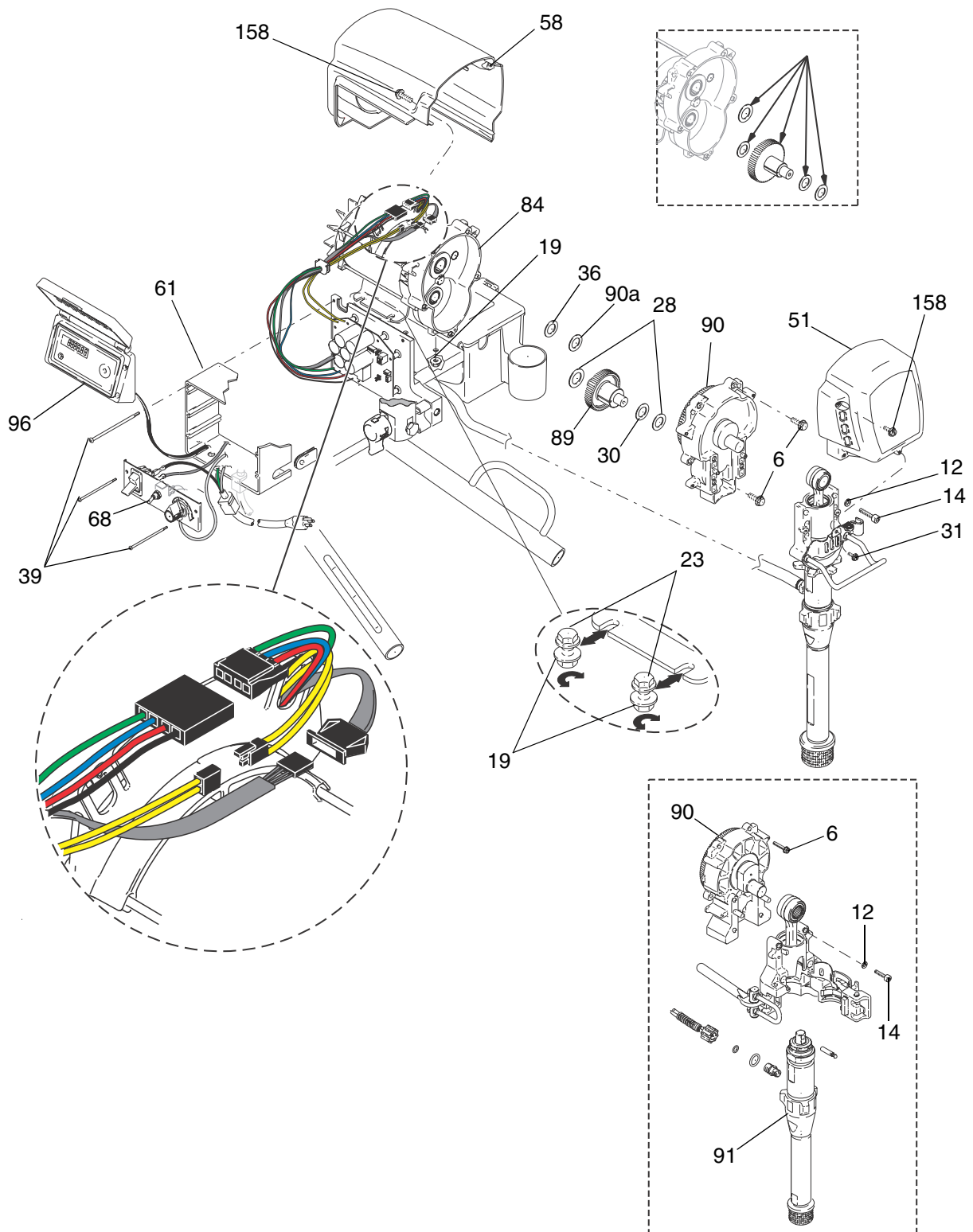

ti14893a

Displacement Pump Replacement for 695/795/Mark IV

See pump manual 310643 or 310894 for pump repair instructions.

See manual 3A0158 for applicable sprayer part number references.

Removal



1. Flush pump.
2. Perform **Relieve Pressure Procedure**; page 8.
3. Remove screw (31) and slide pump rod shield (108) forward.

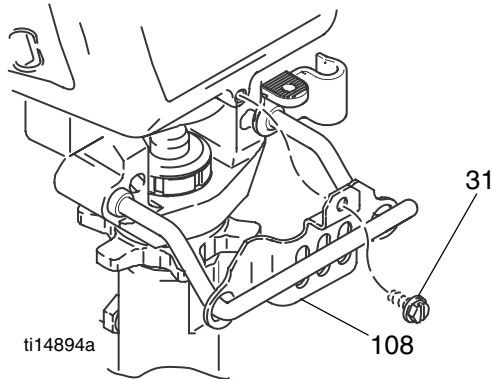

4. Increase pressure slightly to cycle pump in JOG mode until pump pin (44) is in position to be removed. Turn power switch OFF and unplug power cord. Push up retaining ring (43) and push pump pin out.

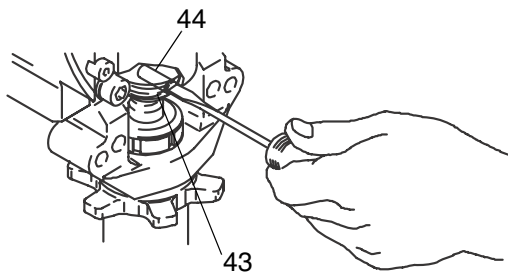

5. Remove suction tube (76), hose (94) and any washers and o-rings.

6. Loosen pump jam nut (56). Unscrew pump.

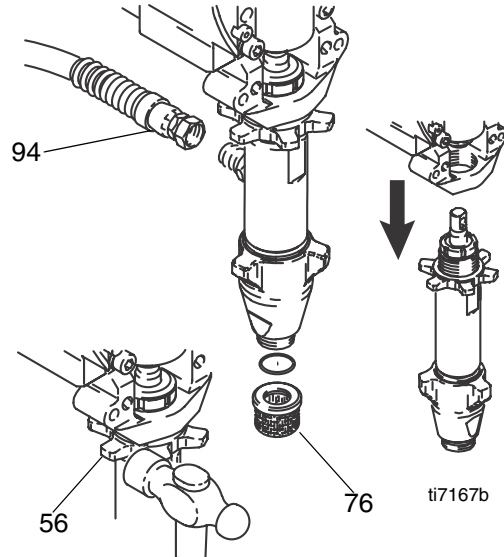

Installation

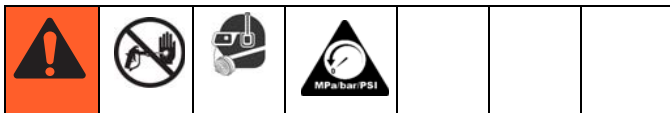

If pump pin works loose, parts could break off due to force of pumping action. Parts could project through the air and result in serious injury or property damage.

NOTICE

If the pump jam nut loosens during operation, the threads of the drive housing will be damaged.

1. Extend pump piston rod 1.5 in. Apply grease to top of pump rod at (A) or inside connecting rod.

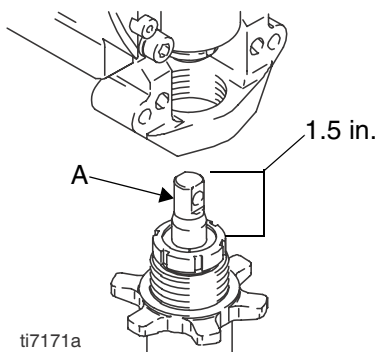

2. Install pump pin (44). Verify retaining spring (43) is in groove of connecting rod (85).
3. Push pump up until pump threads engage.
4. Screw in pump until threads are flush with drive housing opening. Align pump outlet to back.
5. Install washers, o-rings and suction tube (76) and hose (94).
6. Screw jam nut (56) up onto pump until nut stops. Tighten jam nut by hand, then tap 1/8 to 1/4 turn with a 20 oz (maximum) hammer to approximately 75 ± 5 ft-lb (102 N•m).
7. Install pump rod shield (108) with screw (31).

8. Fill packing nut with Graco TSL until fluid flows onto top of seal.

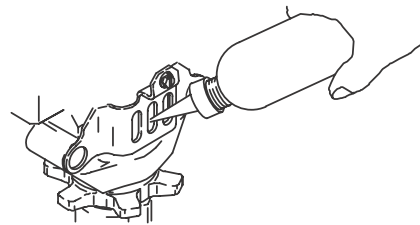

ti7169a

Displacement Pump Replacement 1095/1595/Mark V

Removal



1. Flush pump.
2. Stop pump with piston rod in its lowest position.
3. Perform **Pressure Relief Procedure**, page 8.
4. Separate drain hose from sprayer.

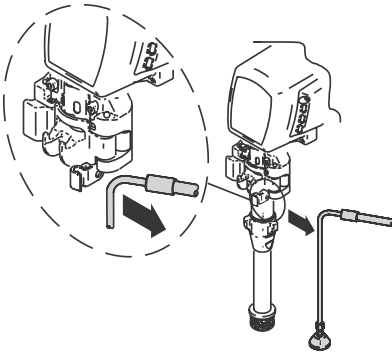

5. Disconnect paint hose from pump.

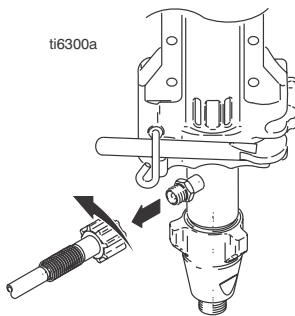

6. Raise latch lock. Push latch open.

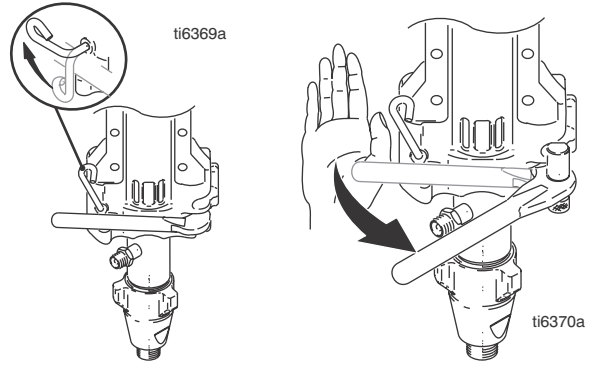

7. Ratchet open pump door.

- a. Ratchet pump door forward.

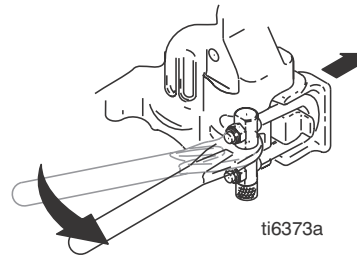

- b. Twist latch u-bolt out of pump door recess.

- c. Place u-bolt on pump door outer edge.

- d. If pump door is stuck, do steps e, f, and 8, otherwise go to step 9.

- e. Twist latch u-bolt back from pump door outer edge.

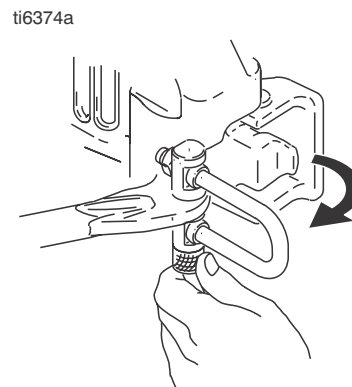

- f. Place u-bolt on pump door protrusion.

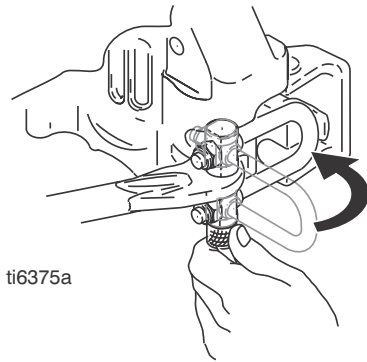

ti6375a

8. Ratchet pump door forward.

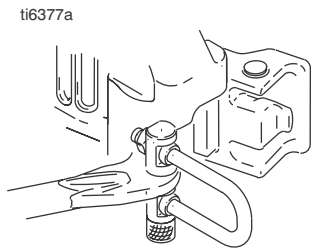

ti6377a

9. Open pump door.

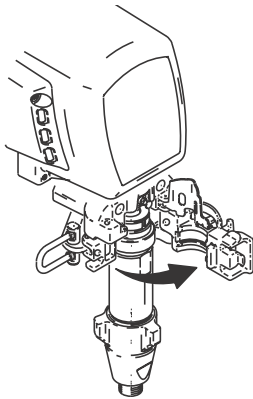

10. Pull out pump pin and place in pin holder.

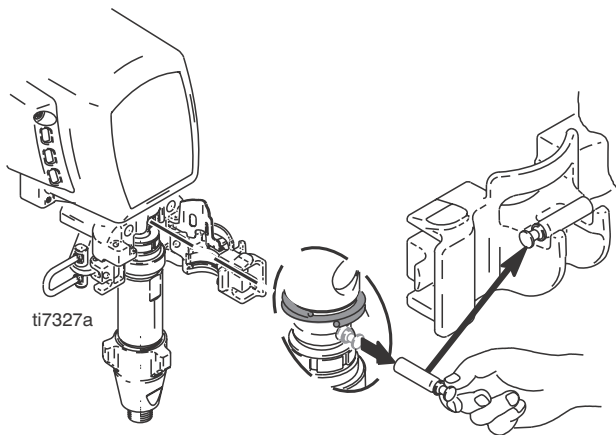

ti7327a

Installation

1. Adjust piston rod with pin holder to pull out piston rod. Tap piston rod on hard surface to push in piston rod.
2. Push pump collar flush with bearing housing ledge to be able to close pump door.

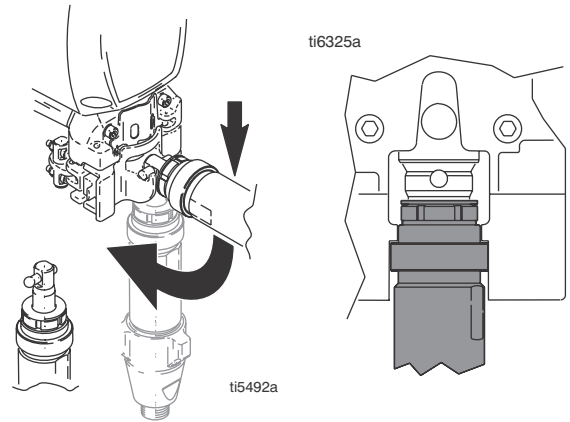

ti6325a

ti5492a

3. Slide pump into connecting rod. Push pump pin until it is fully retained.
NOTE: Pin will snap into position.

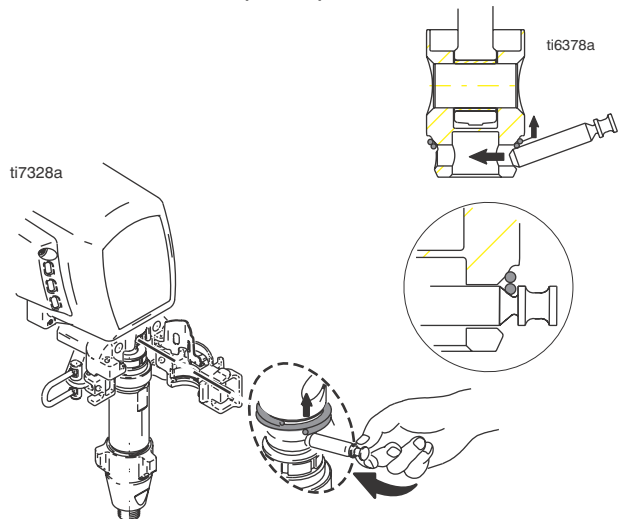

ti6378a

ti7328a

4. Close pump door and rotate latch into position. Do not tighten latch.

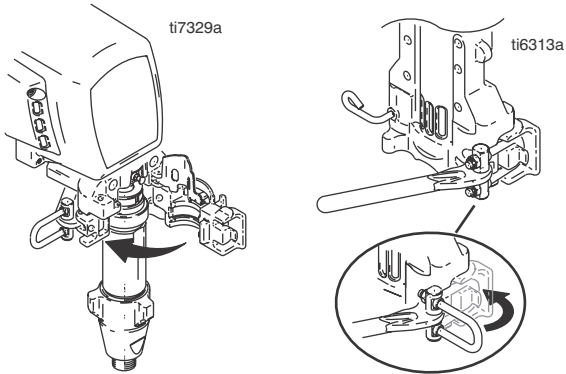

5. Rotate pump to align with paint hose. Connect paint hose and hand tighten to 70 in-lb.

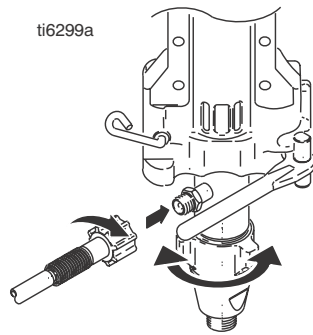

6. Tighten latch and rotate latch lock into locked position.

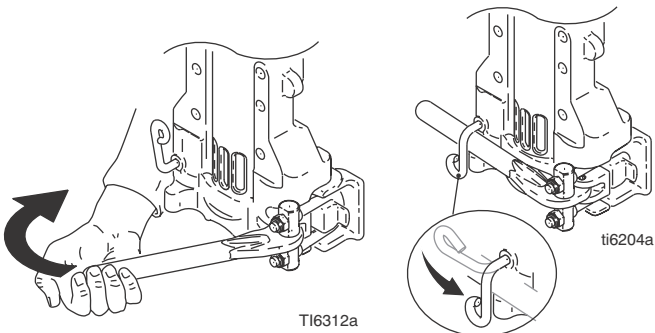

7. Attach drain hose to sprayer.

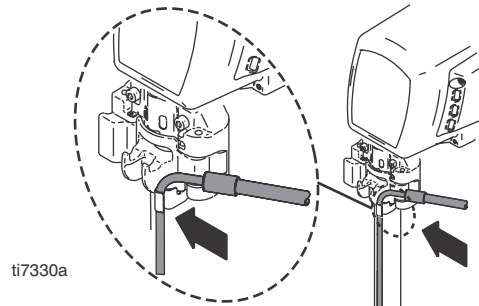

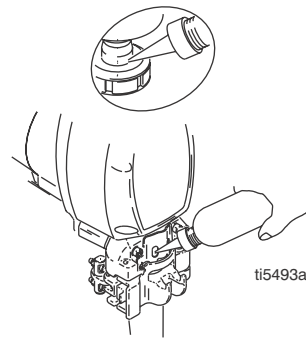

8. Fill pump with Graco TSL until fluid flows onto top of seal.



Hose Reel

Removal

						
Be sure to keep your head clear of hose reel while winding up hose.						

1. Remove hose fitting from swivel cap and completely remove hose.

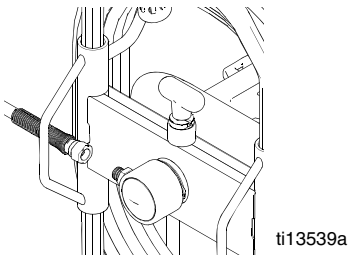

2. Remove cap from swivel.

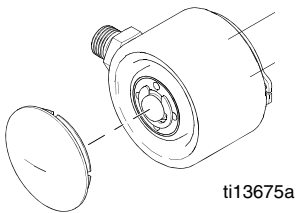

3. Remove E-clip from swivel shaft.

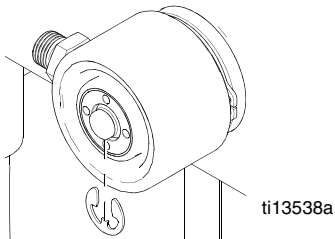

4. Remove swivel.

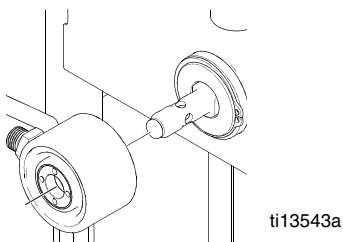

5. Remove snap ring.

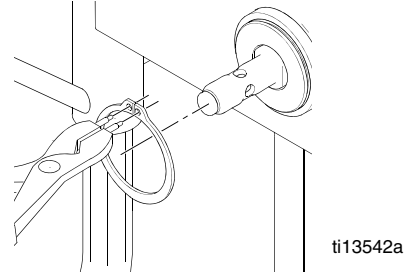

6. Remove hose reel.

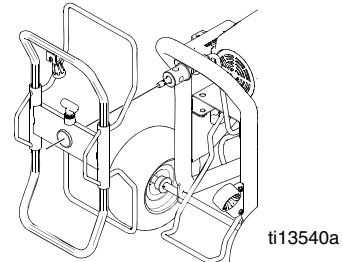

7. Remove rigid fluid tube from swivel shaft (if necessary).

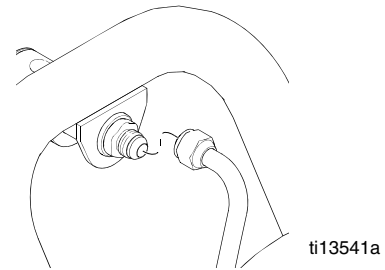

8. Remove swivel shaft (if necessary).

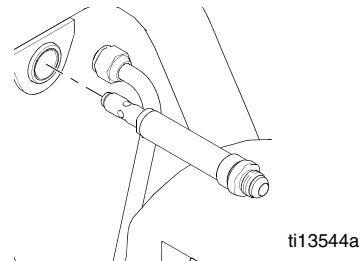

Installation

1. Grease shaft.

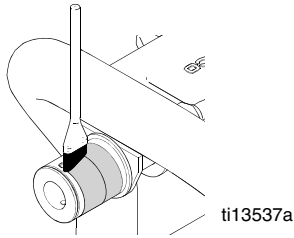

2. Replace swivel shaft if it was removed.

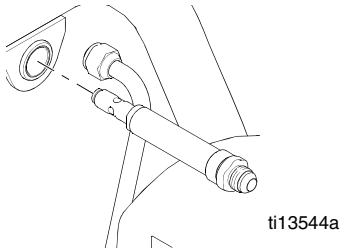

3. Replace rigid fluid tube to swivel shaft if it was removed.

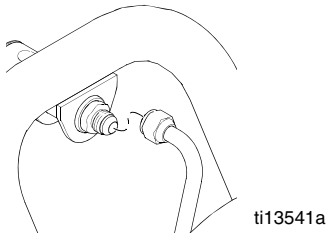

4. Make sure two washers and wave spring are on hub before hose reel is installed.

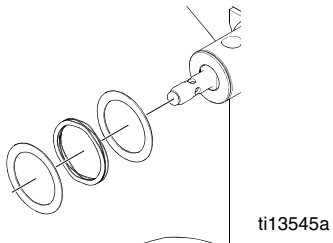

5. Install hose reel onto frame. Place C-clamp on reel and frame to allow snap ring to fit into place. Install snap ring.

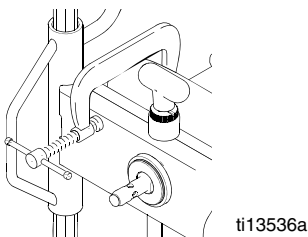

6. Install swivel.

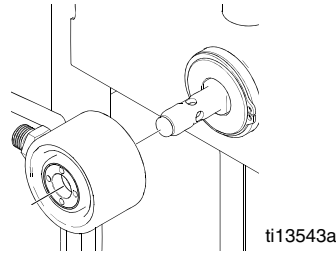

7. Install E-clip and swivel cap.

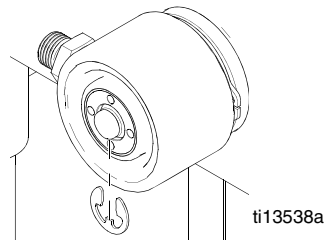

8. Install hose to swivel. Make sure to route hose through side arm of hose reel.

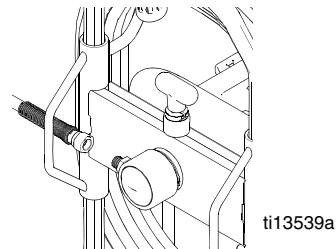

9. Turn hose reel clockwise to wrap up hose. Make sure hose is routed through hose guide.

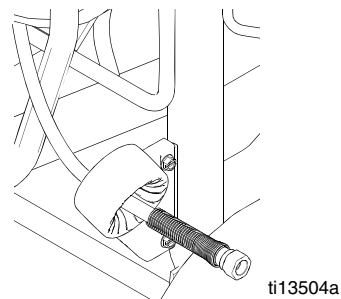

Reed Switch Replacement

Removal

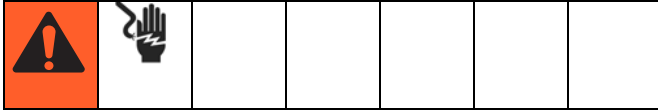

1. Remove four screws and remove display cover.

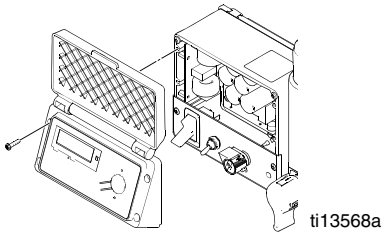

2. Remove two screws and remove control panel.

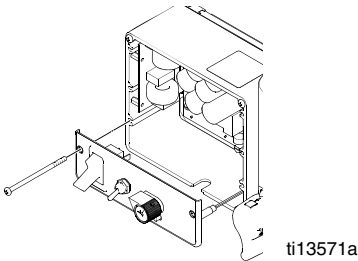

3. Unplug reed switch from control board.

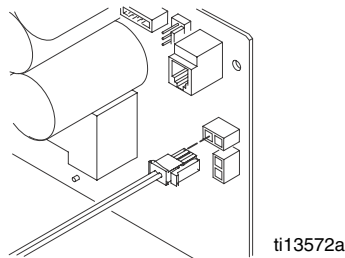

4. Unscrew reed switch from control panel.

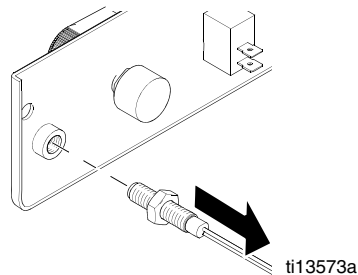

Installation

1. Apply thread sealant to end of reed switch. Hand tighten reed switch until it is tight against control panel.

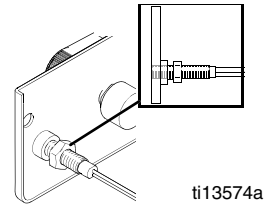

2. Add thread sealant and tighten jam nut against threaded bus.

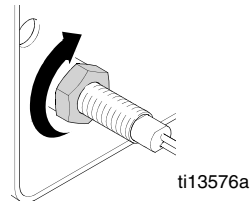

3. Connect reed switch to control board.

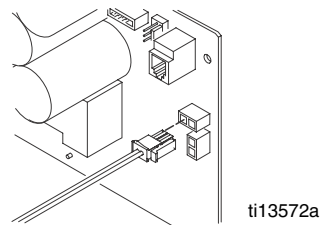

4. Replace control panel and tighten two screws.

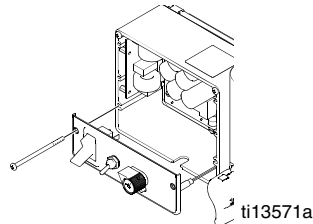

5. Replace display cover and tighten four screws.

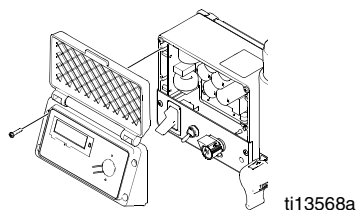

Wiring Diagram

120V Models:

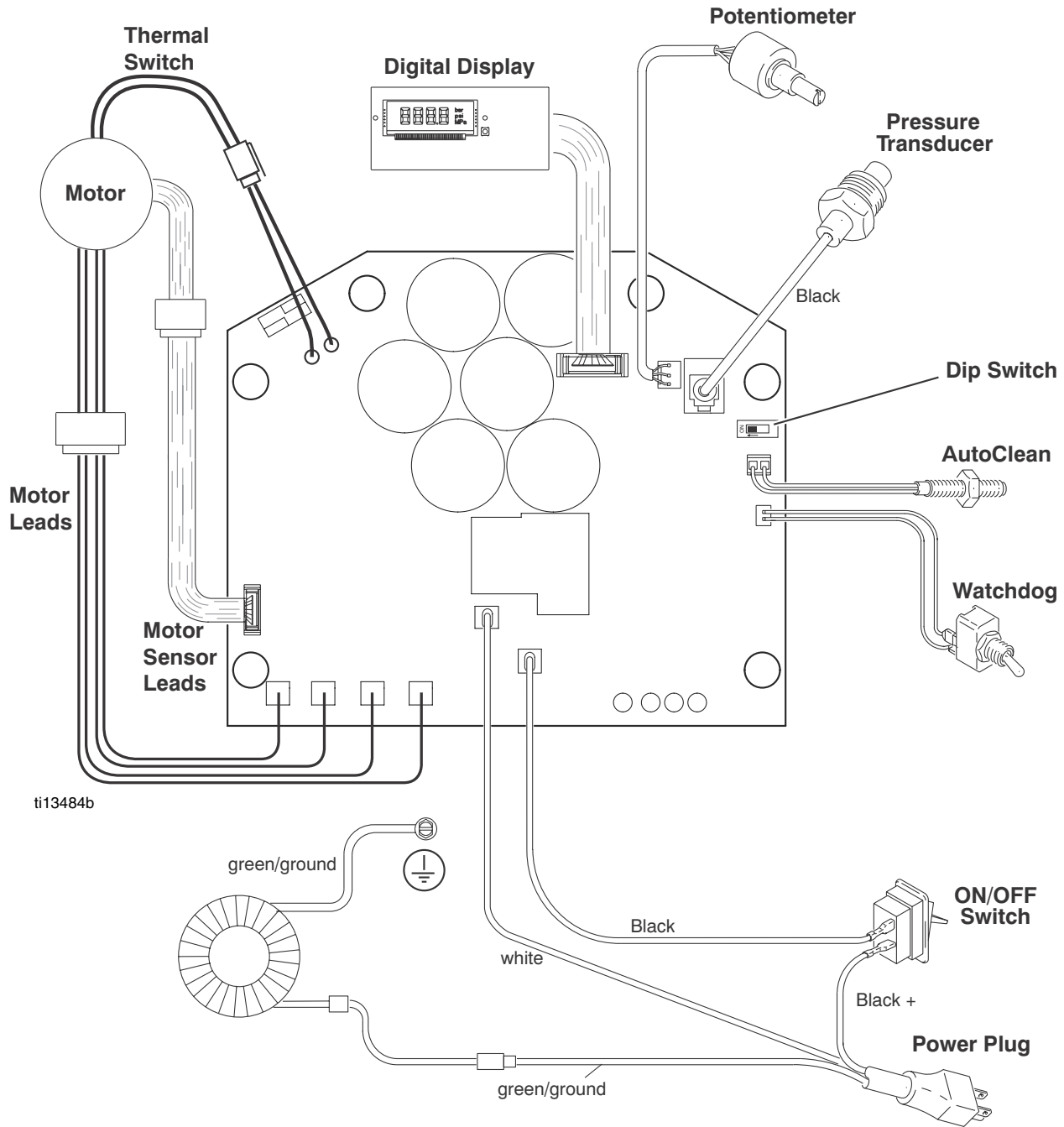

120V Models (with 15/20 Amp Switch):

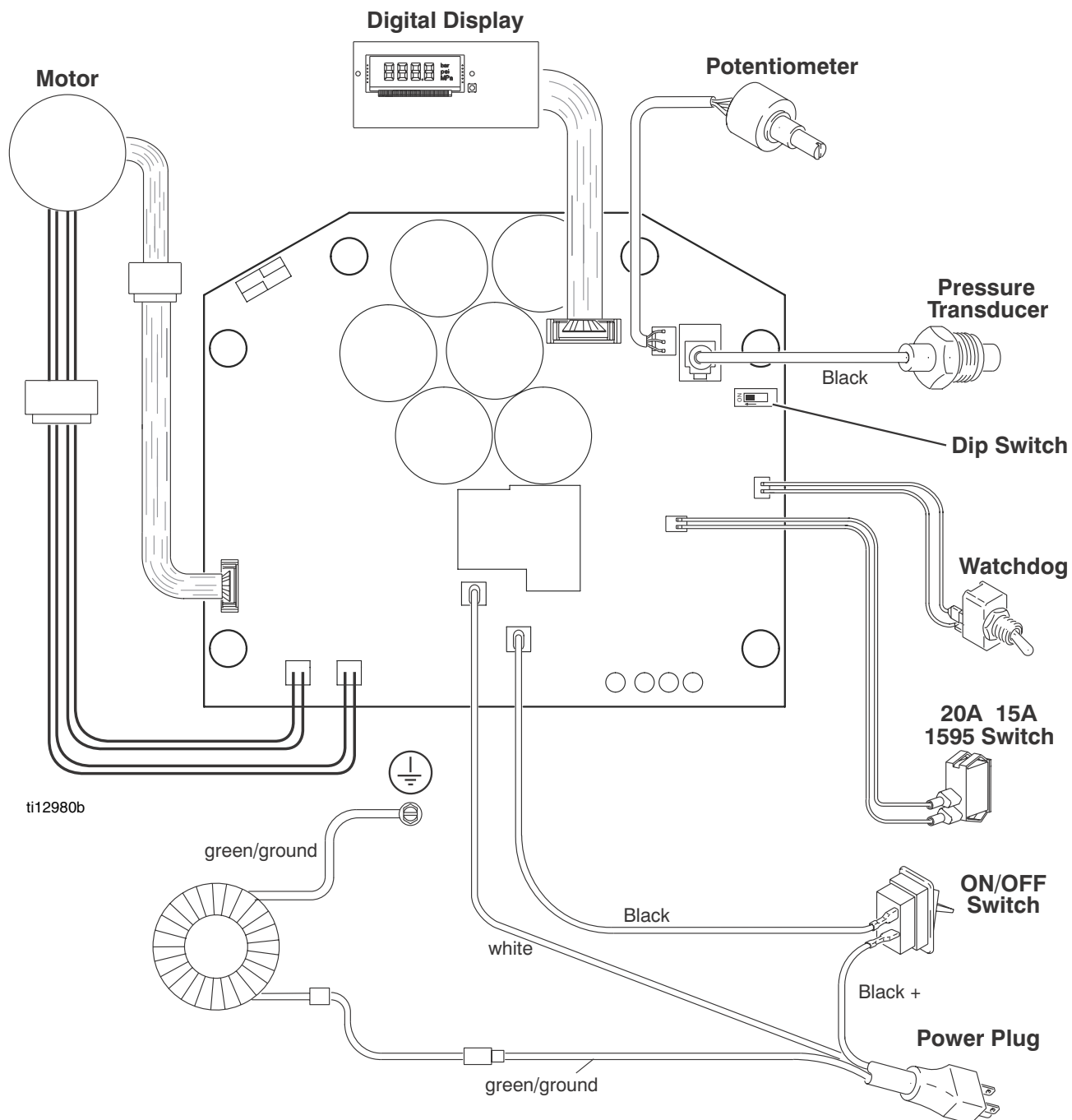

240V Models:

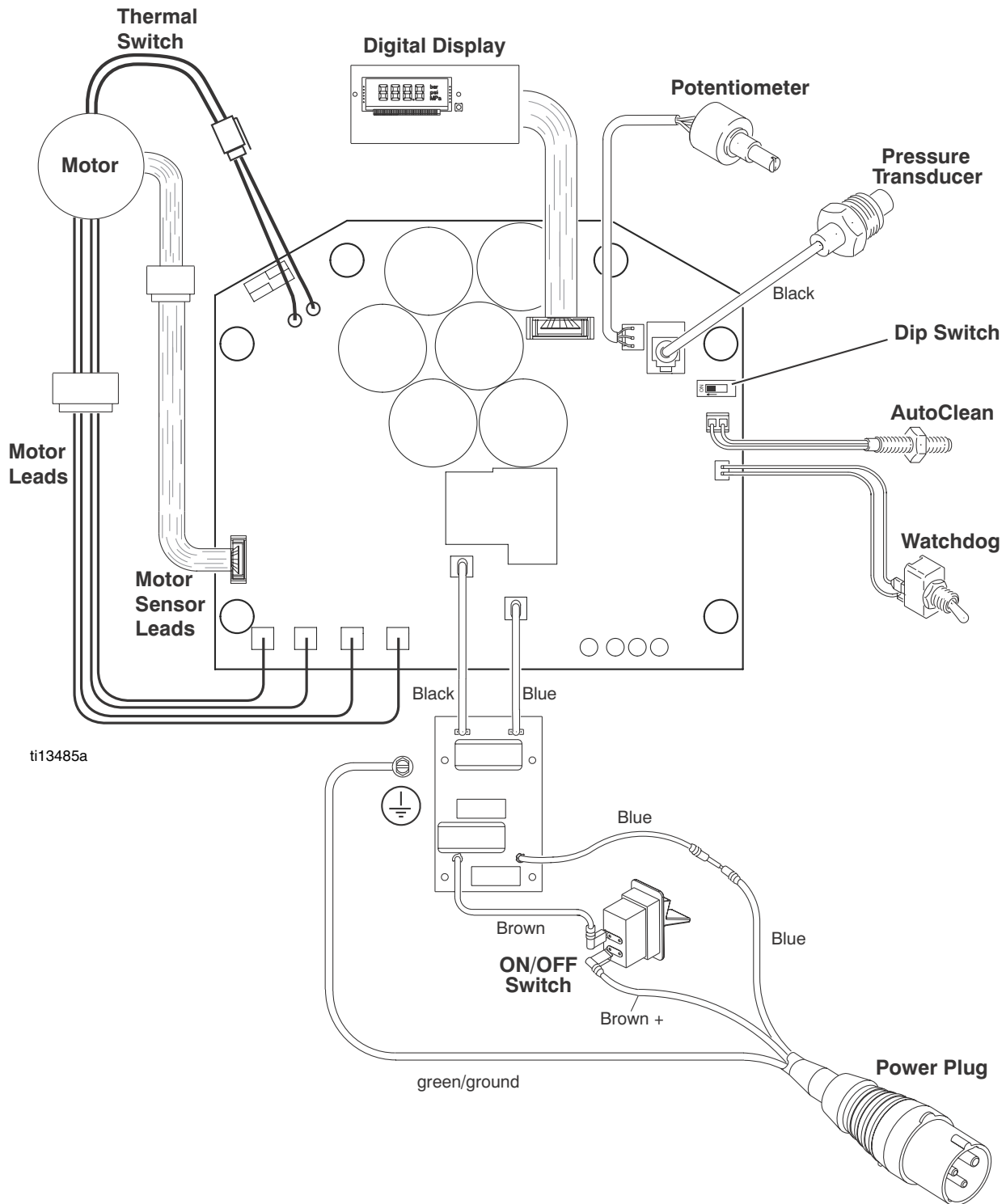

Graco Standard Warranty

Graco warrants all equipment referenced in this document which is manufactured by Graco and bearing its name to be free from defects in material and workmanship on the date of sale to the original purchaser for use. With the exception of any special, extended, or limited warranty published by Graco, Graco will, for a period of twelve months from the date of sale, repair or replace any part of the equipment determined by Graco to be defective. This warranty applies only when the equipment is installed, operated and maintained in accordance with Graco's written recommendations.

This warranty does not cover, and Graco shall not be liable for general wear and tear, or any malfunction, damage or wear caused by faulty installation, misapplication, abrasion, corrosion, inadequate or improper maintenance, negligence, accident, tampering, or substitution of non-Graco component parts. Nor shall Graco be liable for malfunction, damage or wear caused by the incompatibility of Graco equipment with structures, accessories, equipment or materials not supplied by Graco, or the improper design, manufacture, installation, operation or maintenance of structures, accessories, equipment or materials not supplied by Graco.

This warranty is conditioned upon the prepaid return of the equipment claimed to be defective to an authorized Graco distributor for verification of the claimed defect. If the claimed defect is verified, Graco will repair or replace free of charge any defective parts. The equipment will be returned to the original purchaser transportation prepaid. If inspection of the equipment does not disclose any defect in material or workmanship, repairs will be made at a reasonable charge, which charges may include the costs of parts, labor, and transportation.

THIS WARRANTY IS EXCLUSIVE, AND IS IN LIEU OF ANY OTHER WARRANTIES, EXPRESS OR IMPLIED, INCLUDING BUT NOT LIMITED TO WARRANTY OF MERCHANTABILITY OR WARRANTY OF FITNESS FOR A PARTICULAR PURPOSE.

Graco's sole obligation and buyer's sole remedy for any breach of warranty shall be as set forth above. The buyer agrees that no other remedy (including, but not limited to, incidental or consequential damages for lost profits, lost sales, injury to person or property, or any other incidental or consequential loss) shall be available. Any action for breach of warranty must be brought within two (2) years of the date of sale.

GRACO MAKES NO WARRANTY, AND DISCLAIMS ALL IMPLIED WARRANTIES OF MERCHANTABILITY AND FITNESS FOR A PARTICULAR PURPOSE, IN CONNECTION WITH ACCESSORIES, EQUIPMENT, MATERIALS OR COMPONENTS SOLD BUT NOT MANUFACTURED BY GRACO. These items sold, but not manufactured by Graco (such as electric motors, switches, hose, etc.), are subject to the warranty, if any, of their manufacturer. Graco will provide purchaser with reasonable assistance in making any claim for breach of these warranties.

In no event will Graco be liable for indirect, incidental, special or consequential damages resulting from Graco supplying equipment hereunder, or the furnishing, performance, or use of any products or other goods sold hereto, whether due to a breach of contract, breach of warranty, the negligence of Graco, or otherwise.

FOR GRACO CANADA CUSTOMERS

The Parties acknowledge that they have required that the present document, as well as all documents, notices and legal proceedings entered into, given or instituted pursuant hereto or relating directly or indirectly hereto, be drawn up in English. Les parties reconnaissent avoir convenu que la rédaction du présente document sera en Anglais, ainsi que tous documents, avis et procédures judiciaires exécutés, donnés ou intentés, à la suite de ou en rapport, directement ou indirectement, avec les procédures concernées.

For the latest information about Graco products, visit www.graco.com.

TO PLACE AN ORDER, contact your Graco distributor or call 1-800-690-2894 to identify the nearest distributor.

*All written and visual data contained in this document reflects the latest product information available at the time of publication.
Graco reserves the right to make changes at any time without notice.*

This manual contains English. MM 3A0157

Graco Headquarters: Minneapolis
International Offices: Belgium, China, Japan, Korea

GRACO INC. P.O. BOX 1441 MINNEAPOLIS, MN 55440-1441

Copyright 2009, Graco Inc. is registered to ISO 9001

www.graco.com

2009